

**BOEHLERIT**

Member of the LEITZ Group

**Fräsen**

**Milling**



[www.boehlerit.com](http://www.boehlerit.com)

Die Marke Boehlerit wurde 1932 für die Hartmetallfertigung der Firma Böhler in Düsseldorf gegründet. 1950 begann der Aufbau der Hartmetallfertigung in der österreichischen Stahlstadt Kapfenberg, wo sich heute der Hauptstandort der Boehlerit Gruppe befindet. Ein wesentlicher Meilenstein in der Boehlerit Geschichte war die 100%ige Übernahme der gesamten Boehlerit Gruppe durch den Leitz Firmenverband aus Oberkochen / Deutschland im Jahr 1991.

Seitdem hat sich Boehlerit erfolgreich zum Schneidstoffzentrum der Leitz Firmengruppe entwickelt und zählt zu den weltweit führenden Herstellern von Schneidstoffen aus Hartmetall für Werkzeuge zur Holz-, Kunststoff- und Metallbearbeitung sowie von Werkzeugen zum Drehen, Fräsen, Bohren, Drehschalen, Hüttentechnik und der Kurbelwellenbearbeitung.

Eine weitere Stärke von Boehlerit sind Hartmetalle für Konstruktionsteile und für den Verschleißschutz.

Synergien zum Schwesterunternehmen Bilz, dem weltweit führenden Hersteller von Gewindeschneidfuttern, werden zum Vorteil der weltweiten Kunden genutzt.

### **Produktionsstandorte**

Die Boehlerit Gruppe setzt internationale Qualitätsstandards.

In modernsten Produktionsstätten wird jährlich in neue Produktionstechnologien und Kapazitätserweiterungen investiert – in Österreich, Deutschland, Spanien und der Türkei werden die Erkenntnisse aus Forschung und Entwicklung in Qualitätsprodukte umgesetzt.

### **Vertrieb**

Die Boehlerit Gruppe, gemeinsam mit der Bilz Gruppe und exklusiven Vertriebspartnern, ist auf fast allen Kontinenten heimisch. Absolute Kundenorientierung mit schnellem Beratungs- und Lieferservice bei bester Produktqualität, so lautet unser Credo. Verantwortlich dafür sind die jeweiligen hoch spezialisierten Vertriebsgesellschaften mit über 300 geschulten Anwendungsberatern bzw. Vertriebsingenieuren. Erfahrene Außendienstmitarbeiter befinden sich weltweit stets in Rufweite der Kunden und stehen bei Kundenproblemen rasch für Beratung und Service zur Verfügung.

### **Forschung und Entwicklung**

Durch modernste Analysemethoden und in enger Zusammenarbeit mit Universitäten und Forschungseinrichtungen begegnet die Forschungs- und Entwicklungsabteilung von Boehlerit den sich ständig verändernden Anforderungen

(Produktivitätssteigerung, verbesserte Werkstoffe, neue Anwendungsbereiche) an den Schneid- und Verschleißschutzstoff Hartmetall.

Das Resultat dieser intensiven Entwicklungsarbeiten sind neue, hochqualitative und anwendungsorientierte Produkte,

Made by Boehlerit.

## **Boehlerit – Pioneers in Carbide Development**

The Boehlerit brand was established in 1932 for the carbide production of the Böhler company in Düsseldorf. 1950 was the beginning of carbide production in the Austrian steel town of Kapfenberg where the Boehlerit Group's headquarters are located today. The take-over of the entire Boehlerit Group by the Leitz Group from Oberkochen, Germany in 1991 marked an important milestone in the history of Boehlerit. Since its integration into the Leitz Group, Boehlerit has successfully developed into the group's centre for cutting materials.

It is one of the world's leading producers of carbide cutting materials for tools for wood, plastic and metal cutting and tools for turning, milling, drilling, bar peeling, steel industry and crankshaft machining.

Carbide for structural parts and wear protection are yet another core competency of Boehlerit.

Synergies with the affiliated company Bilz, the internationally leading producer of tapping chucks, are utilised to the benefit of customers worldwide.

### **Production sites**

The Boehlerit Group sets international quality standards. Every year, the company invests in new production technologies and in the expansion of capacities at its advanced production sites. High-quality products made in Austria, Germany, Spain and Turkey incorporate the latest research and development findings.

### **Distribution**

Together with the Bilz Group and exclusive partners, Boehlerit Group is represented on nearly all continents. Absolute dedication to its customers, swift consulting and supply service and the highest product quality are its core principles. Our highly specialised distribution organisations with more than 300 qualified application consultants and sales engineers live by these principles, and our experienced field staff is always and everywhere on hand nearby to provide consultation and service for any challenge our customers may be faced with.

### **Research and Development**

The Research and Development department of Boehlerit meets the continuously changing demands (increased productivity, improved materials, new applications) that carbide, as a cutting and wear protection material must fulfil.

It does so with its advanced analytical methods and in close cooperation with universities and research institutions. The result of the company's concentration on development are new application-oriented products of the highest quality – made by Boehlerit.

<b>Programmübersicht Werkzeuge Fräsen</b>	<b>Overview Tools Milling</b>	<b>4</b>
<b>ISO Fräswendeplatten</b>	<b>ISO indexable inserts for milling</b>	
Technologievorteile Fräsen	Technological advantages milling	6
Sortenübersicht / Sortenbeschreibung zum Fräsen	Grade description milling	8
Bezeichnungssysteme	Designation systems	10
Wendeplattenprogramm	Indexable inserts program	14
<b>Fräswerkzeuge</b>	<b>Milling tools</b>	
Fräser 45° für Wendeplatten	Milling cutters 45° for indexable inserts	21
Schnittwertempfehlungen Fräsen 45°	Cutting data recommendations milling 45°	28
Fräser 90° für Wendeplatten	Milling cutters 90° for indexable inserts	31
Schnittwertempfehlungen Fräsen 90°	Cutting data recommendations milling 90°	52
BULLtec Schwerzerspanungsfräser	BULLtec heavy duty face milling cutter	55
<b>Vollhartmetallverlängerungen</b>	<b>Solid carbide extension</b>	<b>69</b>
<b>Technische Hinweise</b>	<b>Technical Hints</b>	
Rampe eintauchen	Ramping	72
Formeln	Formulas	72
Berechnung des Eingriffswinkels $w_s$	Calculation of approach angle $w_s$	73
<b>Anhang</b>	<b>Attachment</b>	
Maße, Einheiten, Anwendungsformeln	Dimensions, units and application formulas	74
Lösungen von Problemen beim Fräsen	Solutions of problems in milling	75
Werkstoffe-Vergleichstabelle	Material comparison chart	76
<b>Vertriebsgesellschaften</b>	<b>Sales organisations</b>	<b>80</b>



**Kapfenberg** in der Steiermark / **ÖSTERREICH** in Styria / **AUSTRIA**

Nachdruck, auch auszugsweise, ist nur mit unserer Zustimmung gestattet. Alle Rechte vorbehalten. Irrtümer, Satz- oder Druckfehler berechtigen nicht zu irgendwelchen Ansprüchen. Abbildungen, Ausführungen und Maße entsprechen dem neuesten Stand bei Herausgabe dieses Kataloges. Technische Änderungen müssen vorbehalten sein. Die bildliche Darstellung der Produkte muss nicht in jedem Falle und in allen Einzelheiten dem tatsächlichen Aussehen entsprechen.  
This publication may not be reprinted in whole or part without our express permission. All right reserved. No rights may be derived from any errors in content or from typographical or typesetting errors. Diagrams, features and dimensions represent the current status on the date of issue of this catalogue. We reserve the right to make technical changes. The visual appearance of the products may not necessarily correspond to the actual appearance in all cases or in every detail.

**Plitec 45N**  
Ø 50 - 160  
für for ONMU....  
Seite Page 22

**ISO 45P**  
Ø 40 - 125  
für for SE....  
Seite Page 26

**45°**

**90°**

**DELTAtec 90N Tang**  
Ø 50 - 80  
für for LNMX....  
Seite Page 50

**BETAtec 90P Feed**  
Ø 16 - 80  
für for LDMX....  
Seite Page 32

**ISO 90P**  
Ø 12 - 125  
für for APKT....  
Seite Page 42

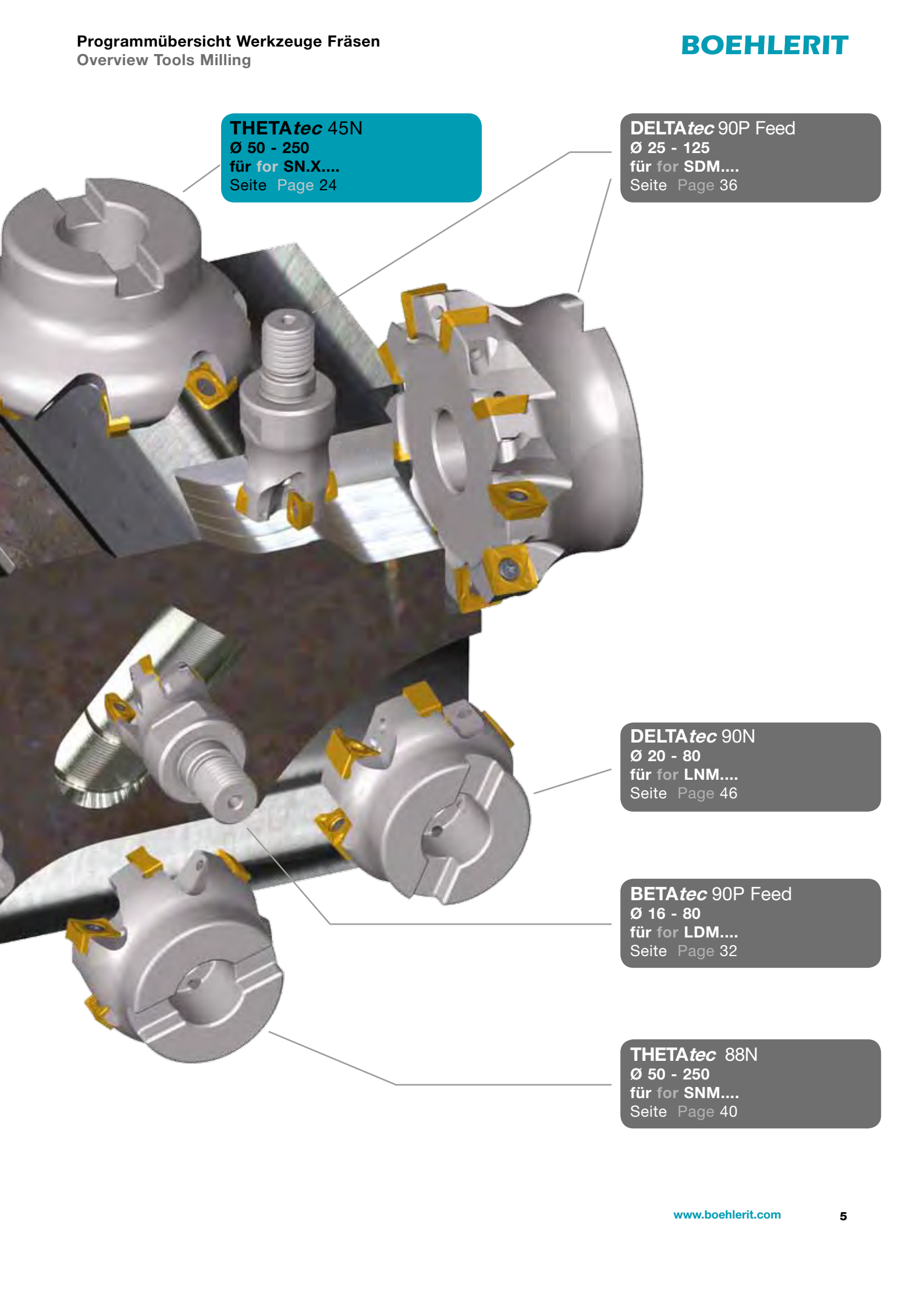

**THETAtec 45N**  
Ø 50 - 250  
für for SN.X....  
Seite Page 24

**DELTAtec 90P Feed**  
Ø 25 - 125  
für for SDM....  
Seite Page 36

**DELTAtec 90N**  
Ø 20 - 80  
für for LNM....  
Seite Page 46

**BETAtec 90P Feed**  
Ø 16 - 80  
für for LDM....  
Seite Page 32

**THETAtec 88N**  
Ø 50 - 250  
für for SNM....  
Seite Page 40



**Technologievorteile Fräsen**  
**Technological advantages milling**

**Kundennutzen**  
**Customer benefits**

<p>Große Schneidstoffvielfalt im Portfolio, um dem breiten Materialspektrum gerecht zu werden - daraus resultieren optimale Zerspanungsverhältnisse.</p> <p>The biggest range of cutting grades for dealing with a very broad spread of materials enables us to ensure optimum cutting conditions.</p>		<p>Hohe Wirtschaftlichkeit und Bearbeitungssicherheit auf einem breiten Werkstoffspektrum.</p> <p>High economic machining and security on a wide range of material.</p>
<p>Patentierte neuartige TERASpeed 2.0 AlTiN-Schicht, abgeschieden mittels HR-CVD Technologie (HR = High Reactivity).</p> <p>Patented new TERASpeed 2.0 AlTiN layer, deposited by means of HR-CVD technology (HR = High Reactivity).</p> <p>MT - CVD Nano schwarz          MT - CVD Nano black</p> <p>HR - CVD TERASpeed 2.0          HR - CVD TERASpeed 2.0</p>		<p>Auf Grund des hohen Aluminiumgehalts dieser AlTiN-Schicht und ihrer neuartigen Nanostruktur konnten erstmals so gegenläufige Eigenschaften, wie eine hohe Zähigkeit mit gleichzeitig extremer Schichthärte und Verschleißbeständigkeit kombiniert werden.</p> <p>The high aluminium content of this AlTiN coat and its innovative nanostructure make it possible, for the first time, to combine properties that are as such opposing – such as toughness, outstanding layer hardness and wear resistance.</p>
<p>Goldlox          Dicke PVD-AlTiN-Beschichtung. Hoher Aluminiumgehalt bewirkt hohe Verschleißbeständigkeit bei höheren Temperaturen. Beschichtung mit besonders glatter Oberfläche und TiN-Deckschicht zur Verschleißerkennung. Goldlox          Thick AlTiN coating. High aluminium content procures big wear resistance at higher temperatures. Coating with especial smooth surface and TiN top layer for wear recognition.</p>		<p>Erhöhte Standzeit bei unterschiedlichen Stählen sowie einfache Verschleißerkennung.</p> <p>Increased tool life on different steels as well as simple wear recognition.</p>
<p>Rohstoffe          Boehlerit bezieht ausschließlich Rohstoffe die von qualifizierten Herstellern aus konfliktfreien Mineralien hergestellt werden, um daraus Schneidstoffe für höchste Ansprüche herzustellen.</p> <p>Raw materials          Boehlerit only procures raw materials produced by qualified manufacturers from no-conflict minerals and uses them to produce cutting grades for the most exacting demands.</p>		<p>Fair Partner          Fair partner</p>

**Technologievorteile Fräsen**  
**Technological advantages milling**

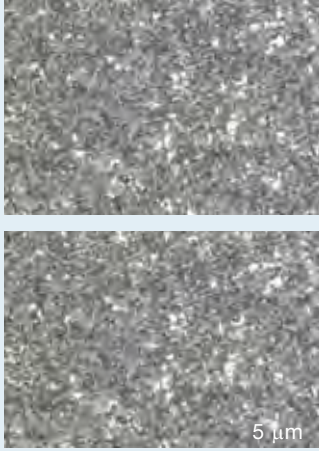
**Kundennutzen**  
**Customer benefits**

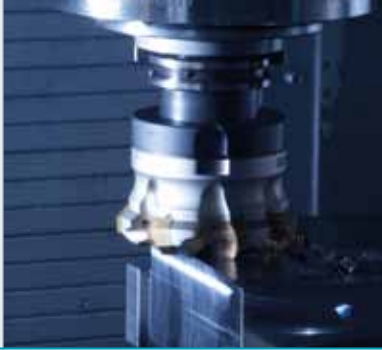
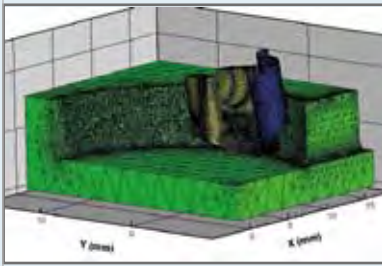
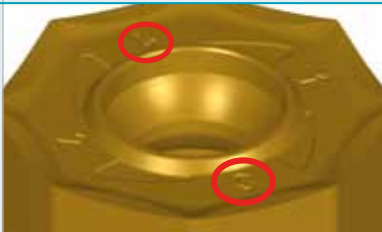
<p><b>Substrate</b>          Zur Herstellung des Fräsprogramms werden verschiedene Hartmetallsubstrate verwendet, die so aufeinander abgestimmt sind, dass ein breites Anwendungsfeld von Schruppen bis Schlichten, Guss, Stahl Rostfreimaterialien und Aluminium mit Plan- und Eckfräsern lückenlos bearbeitet werden kann.</p> <p><b>Substrates</b>          Various carbide substrates are used to produce the range of milling grades fine-tuned to cover an extensive range of applications: from roughing to finishing, from cast to stainless steel materials and aluminium, from face to step milling.</p>		<p>Damit ist sichergestellt, dass jeder Kundenanforderung, egal ob weniger Freiflächenverschleiß, Stabilität gegen Schneidkantenausbrüche, Kammriss- oder Kolkbeständigkeit optimal begegnet werden kann.</p> <p>This is how we ensure that every customer requirement is met: be it minimal flank wear, resistance to chipping of the cutting edge, resistance to thermal cracking or crater wear</p>
<p><b>Multifunktionale Werkzeugsysteme</b>          Multi functional tool systems</p>		<p>Ein Grundkörper.          Zwei Bearbeitungen.          Einsparung von Trägerkörpern und Lagerkosten.</p> <p>One carrier.          Two machinings.          Saving of bodies and stock costs.</p>
<p><b>High End Werkzeuge</b>          High End Tools</p>		<p>Exakte Rundlaufeigenschaften, alle Werkzeuge mit innerer Kühlmittelzuführung.          Nickel implantiert, verbesserte Dauerfestigkeit der Fräsergrundkörper durch spezielle Werkstoffe und Wärmebehandlungen.</p> <p>Exact true running characteristics, all tools with internal coolant supply.          Nickel implanted          Improved endurance strength of the milling body due to special material and through heat treatment.</p>
<p><b>Dynamische FEM Design</b>          (Finite Elemente Methode) Technologie.</p> <p>Dynamic FEM Design          (Finite Elemente Method) technology</p>		<p>Stabile Werkzeuge mit exzellenten Dauerfestigkeitseigenschaften und optimalen Spanablauf</p> <p>Stable tools with excellent endurance strengths characteristics and optimized chip flow</p>
<p>Größe des Eckenradius in der Platte mitgepresst und Markierung zur Positionierung bzw. Nummerierung der Schneiden</p> <p>Size of the corner radius pressed in the insert and marking for positioning and/or numbering of cutting edges</p>		<p>Leichte Orientierung für die Anwender und gute Rundlaufeigenschaften</p> <p>Easy orientation for the operator and good true running characteristics</p>

Sorte Grade	ISO	Anwendungsbereich Range of applications	Werkstoffgruppe Group of materials						Bearbeitungsverfahren Application				Farbliche Darstellung der WSP je nach Beschichtung Color guide for inserts depending on coating
			P Stahl Steel	M Rostfrei Stainless	K Grauguss Iron	N NE-Metalle (Al, etc.) Various metals	S Hochwärmest. High temper- ature materials	H Harte Werkstoffe Hard mate- rials	T Drehen Turning	M Fräsen Milling	D Bohren Drilling	S Gewinde- bearbeitung Threading	
<b>BCP20M</b>	HC-P20		■								●		
<b>BCP25M</b>	HC-P25		■								●		
	HC-M25			□							●		
	HC-K25				□						●		
<b>BCP30M</b>	HC-P30			■							●		
<b>BCP35M</b>	HC-P35		■								●		
	HC-M35			□							●		
<b>BCP40M</b>	HC-P40		■								●		
	HC-M45			□							●		
<b>BCM35M</b>	HC-M35			■							●		
	HC-S35							□			●		
<b>BCM40M</b>	HC-M40			■							●		
<b>BCK15M</b>	HC-K15				■						●		
<b>BCK20M</b>	HC-K20				■						●		
	HC-P10		□								●		
<b>BCN10M</b>	HC-N10					■					●		
	HC-S20							□			●		
<b>BWN10M</b>	HW-N10					■					●		

Anwendungsschwerpunkt  
Application peak

Gesamtbereich nach ISO 513  
Full range to ISO 513

■ Hauptanwendung  
Main application

□ Weitere Anwendung  
Further applications

● Standardsorte  
Standard grade



● **BCP20M (HC-P20) TERAspeed 2.0**

Härtere Alternative mit HR-CVD zur Sorte BCP25M, mit hohem Widerstand gegen Abrasivverschleiß. Ausgezeichnet geeignet für die Planfräsbearbeitung von Stahlmaterialien mit erhöhter Schnittgeschwindigkeit, unter stabilen Bedingungen.

● **BCP25M (HC-P25/M25) Goldlox**

Mehrbereichssorte zum Fräsen von unlegiertem, niedrig legiertem, hoch legiertem und rostfreiem Stahl. Die PVD beschichtete Sorte eignet sich besonders für hohe Schnittgeschwindigkeiten bei der Trockenbearbeitung / Nassbearbeitung unter stabilen Bedingungen.

● **BCP30M (HC-P30) TERAspeed 2.0**

Universelle Stahlfräsorte vor allem zum Planfräsen. Hohe Bearbeitungssicherheit auf einem breiten Stahlwerkstoffspektrum wird durch das besonders zähe Hartmetallsubstrat garantiert. Eine moderne HR-CVD Beschichtung bietet wirtschaftliche Trockenbearbeitung bei hohen Schnittgeschwindigkeiten.

● **BCP35M (HC-P35/M35) Goldlox**

Universelle Stahlfräsorte in Kombination mit Anstellwinkel 90°. Eine PVD Schicht und eine zähe Hartmetallsorte zum Fräsen von den gängigen Stahlsorten. Besonders gut geeignet zum Trockenfräsen bei niedrigen bis mittleren Schnittgeschwindigkeiten unter schwierigen Bedingungen.

● **BCP40M (HC-P40/M45) Goldlox**

Eine PVD Schicht und zähe Hartmetallsorte zum Schruppen von vor allem Werkzeug-, Vergütungs-, Einsatzstählen und austenitisch, rostfreien Materialien.

● **BCM35M (HC-M35/S35)**

Verschleißfeste PVD-Beschichtung, Feinkornsorte zur Bearbeitung von rostfreien und austenitisch rostfreien Materialien, zur Nass- und Trockenbearbeitung geeignet.

● **BCM40M (HC-M40)**

Extrem zähes, relativ feinkörniges Hartmetallsubstrat mit dünner, glatter PVD Beschichtung. Ideale Sorte zum Fräsen von austenitisch rostfreien Stählen und Werkstoffen aus der Duplexgruppe mit niedrigen bis mittleren Schnittgeschwindigkeiten. Auch für die Nassbearbeitung, jedoch wird Minimalmengenschmierung empfohlen.

● **BCK15M (HC-K15) TERAspeed 2.0**

Ausgesuchte Rohstoffe für ein optimiertes K15-Hartmetallsubstrat mit einer extrem harten und verschleißfesten HR-CVD Mehrlagenbeschichtung. Ideal geeignet für die Trockenbearbeitung von Grauguss (GJL), Kugelgraphitguss (GJS), Temperguss und legiertem Guss.

● **BCK20M (HC-K20/P10)**

Zähes K20 - Substrat und eine dicke PVD-Beschichtung für die Bearbeitung von Gussmaterialien. Auch als Schlichtsorte für die Stahlzerspanung und für die Bearbeitung von Kaltarbeitsstählen härter als 54 HRC geeignet.

● **BCN10M (HC-N10/S20)**

Ideale Sorte für die Bearbeitung von Aluminiumwerkstoffen und weiteren NE-Metallen. Durch eine hauchdünne PVD TiAlN-Schicht ebenfalls hervorragend für die Schlichtzerspanung von rostfreien Stählen und Grauguss geeignet.

● **BWN10M (HW-N10)**

Unbeschichtete Sorte für die Bearbeitung von NE-Metallen sowie Aluminium.

● **BCP20M (HC-P20) TERAspeed 2.0**

Harder alternative to the BCP25M grade, with HR-CVD; high resistance to abrasive wear. Perfectly suited for face milling of steel materials at higher cutting speed under stable conditions.

● **BCP25M (HC-P25/M25) Goldlox**

Multi purpose grade for milling unalloyed, low alloyed, high alloyed and stainless steel. The PVD coated grade is especially suitable for high cutting speeds on dry / wet machining under stable conditions.

● **BCP30M (HC-P30) TERAspeed 2.0**

Universal steel milling grade especially for plain milling. The very tough carbide substrate guarantees high machining security on a wide range of steel materials. A modern HR-CVD coating ensures economic dry machining on high cutting speeds.

● **BCP35M (HC-P35/M35) Goldlox**

Universal steel milling grade in combination with 90° approach angle. A PVD layer and a tough carbide grade for milling of the most usual steel qualities. Especially good suitable for dry milling at low to medium cutting speeds under difficult conditions.

● **BCP40M (HC-P40/M45) Goldlox**

A PVD-layer plus heavy-duty carbide grade for roughing of mainly tool, heat-treated and case-hardened steel, as well as austenitic, stainless materials.

● **BCM35M (HC-M35/S35)**

Wear-resistant PDV coating, fine-grain grade for machining stainless and austenitic stainless materials; suitable for wet and dry machining.

● **BCM40M (HC-M40)**

Extremely tough, relative fine grained carbide substrate with thin, smooth PVD coating. Ideal grade for milling of austenitic stainless steels and materials from the Duplex group with low to medium cutting speeds. Also for wet machining, although minimum coolant supply is recommended.

● **BCK15M (HC-K15) TERAspeed 2.0**

Selected raw materials for optimised K15 carbide substrate with a particularly hard and wear-resistant HR-CVD multi-layer coating. Ideal for dry machining of grey cast iron (GJL), spheroidal graphite cast iron (GJS), tempered cast iron and alloyed cast iron.

● **BCK20M (HC-K20/P-10)**

Tough K20 substrate and a thick PVD coating for the machining of cast materials. Also suited as finishing grade for steel cutting and the machining of cold work steels of 54 HRC.

● **BCN10M (HC-N10/S-20)**

Ideal grade for machining aluminium materials and other non ferrous metals. Due to the ultra-thin PVD TiAlN layer perfectly well suited for finishing stainless steels and grey cast iron.

● **BWN10M (HW-N10)**

Uncoated grade for the machining of non ferrous metals and aluminium.

Fräserbezeichnung  
Cutter designation system

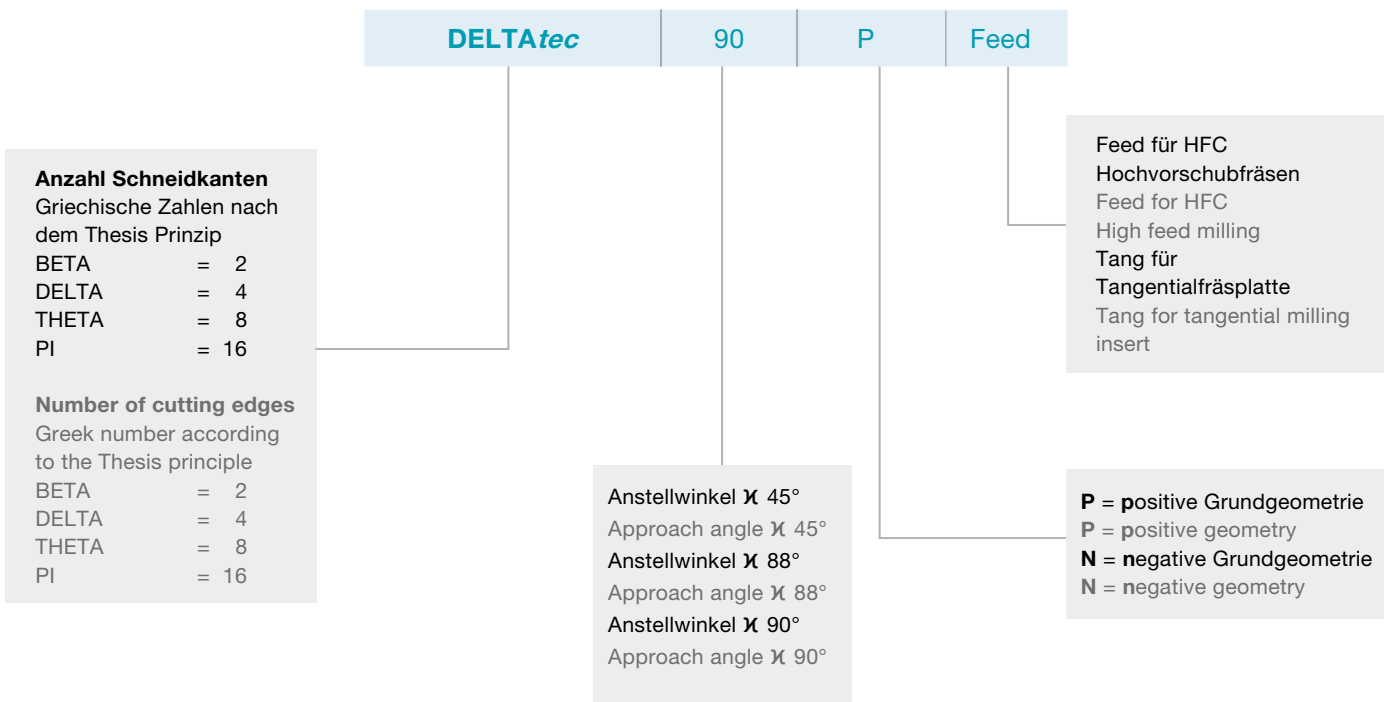
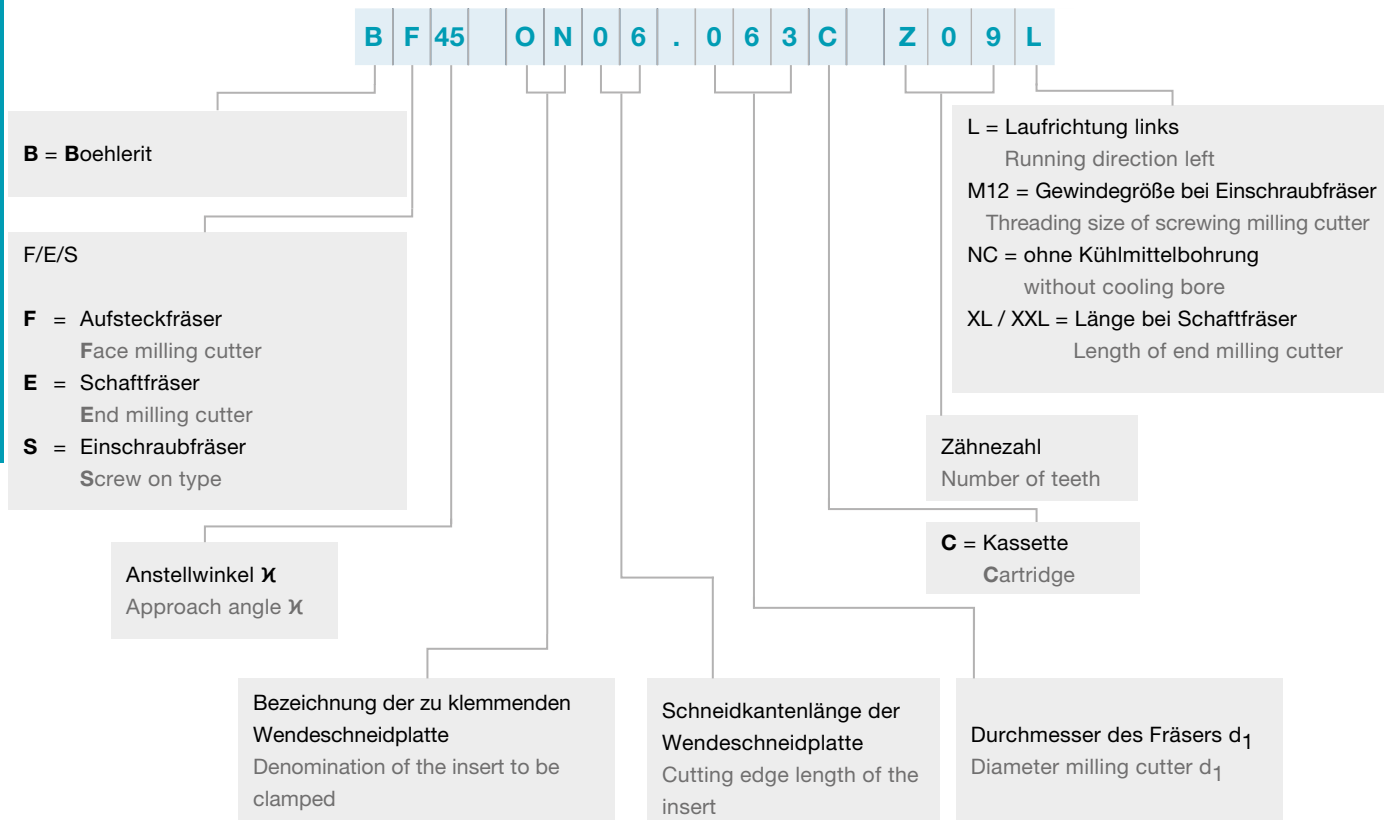

**Schneidstoffsorten, Bezeichnung**  
Cutting materials, designation system

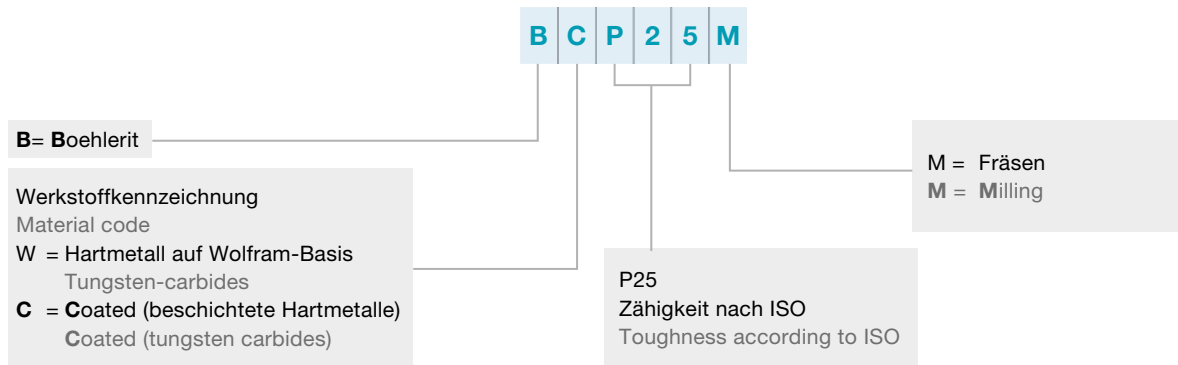

**Vollhartmetall-Verlängerungen, Bezeichnung**  
Solide carbide extension, designation system

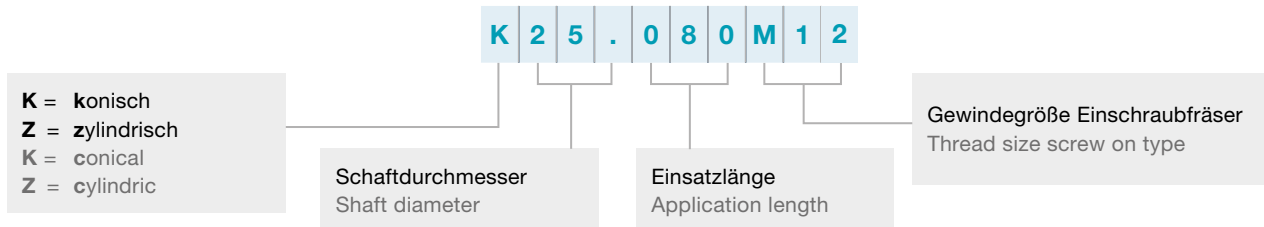

**Symbolerklärung für Fräsoperationen**  
Symbols for milling operations

Planfräsen  
Face milling



Tauchfräsen  
Plunge milling



Gassenfräsen  
Pocket milling



Zirkularfräsen  
Circular milling

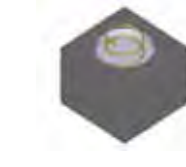

Eckfräsen  
Edge milling

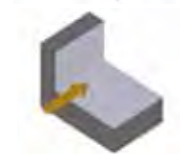

Taschenfräsen  
Pocketing



Nutfräsen  
Slot milling



Rampe eintauchen  
Ramp dipping



Besäumen  
Trimming



Kopierfräsen  
Copy milling



Fasen  
Chamfering



**S**  
Grundform  
Insert shape

A		85°
B		82°
C		80°
D		55°
E		75°
H		120°
K		55°
L		90°
M		86°
O		135°
P		108°
R		-
<b>S</b>		<b>90°</b>
T		60°
V		35°
W		80°

Der Eckenwinkel ist bei ungleichwinkligen Grundformen immer der kleinere Winkel.  
The corner angle is in the case of not equiangular basic forms always the smaller angle.

**N**  
Freiwinkel  
Clearance angle

$\alpha_n$

$\alpha_n$

A	3°
B	5°
C	7°
D	15°
E	20°
F	25°
G	30°
<b>N</b>	<b>0°</b>
P	11°
O	

Normalfreiwinkel, die eine besondere Beschreibung erfordern.  
Normal clearance angles, which require a special description.

**M**  
Toleranzen  
Tolerances

	m	s	d
A	±0,005	±0,025	±0,025
C	±0,013	±0,025	±0,025
E	±0,025	±0,025	±0,025
F	±0,005	±0,025	±0,013
G	±0,025	±0,13	±0,025
H	±0,013	±0,025	±0,013
J	±0,005	±0,025	siehe see Tab. 4
K	±0,013	±0,025	siehe see Tab. 4
L	±0,025	±0,025	siehe see Tab. 4
<b>M</b>	siehe see Tab. 5	±0,13	siehe see Tab. 4
<b>N</b>	siehe see Tab. 5	±0,025	siehe see Tab. 4
U	siehe see Tab. 5	±0,13	siehe see Tab. 4

**Tab. 4**

d		J, K, L, M	U
über	bis		
over	up to		
3,9	10,0	±0,05	±0,08
10,0	15,0	±0,08	±0,13
15,0	20,0	±0,10	±0,18
20,0	26,0	±0,13	±0,25
26,0	32,0	±0,15	±0,25

**Tab. 5**

d		M, N	m	U
über	bis			
over	up to			
3,9	10,0	±0,08		±0,13
10,0	15,0	±0,13		±0,20
15,0	20,0	±0,15		±0,27
20,0	26,0	±0,18		±0,38
26,0	32,0	±0,20		±0,38

Eckenrundung, ungerade Seitenzahl  
Corner rounding uneven number of sides

Eckenrundung, gerade Seitenzahl  
Corner rounding, even number of sides

Fasenplatten  
Chamfered inserts

**X**  
Spanformer, Befestigung  
Chip breaker, fixation

A	
B	(70° - 90°) 
C	(70° - 90°) 
F	
G	
H	(70° - 90°) 
J	(70° - 90°) 
M	
N	
Q	(40° - 60°) 
R	
T	(40° - 60°) 
U	(40° - 60°) 
W	(40° - 60°) 

**X** mit Besonderheit nach Zeichnung  
with special feature acc. to drawing

**12**  
Schneidenlänge  
Cutting edge length

	l
06	6,350
07	7,938
09	9,525
11	11,000
<b>12</b>	<b>12,700</b>
15	15,875
16	16,500
19	19,050
22	22,000
25	25,400
31	31,750
38	38,100

( ) Kegelwinkel für Schraube  
( ) Cone angle for screw

**06**  
Dicke  
Thickness



	<b>S</b>
02	2,38
03	3,18
T3	3,97
04	4,76
05	5,56
<b>06</b>	6,35
07	7,94
08	8,00
09	9,52

Abmessungen in mm  
Dimensions in mm

**AN**  
Schneidenecke  
Cutting edge corner

Für Radiusplatten  
For radius inserts

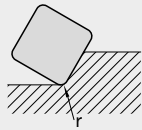

	Eckradius-r Corner radius-r
00	scharfkantig sharp-edged
02	0,2
04	0,4
<b>08</b>	0,8
12	1,2
16	1,6
20	2,0
	usw. etc.

Für Fasenplatten  
Planschneiden  
For chamfered  
inserts face milling

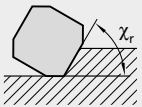

	Anstellwinkel Approach angle
	$\chi_r$
<b>A</b>	45°
D	60°
E	75°
F	85°
P	90°
Z	Sonder Special
	Freiwinkel der Planschneide Clearance angle of face milling edge $\alpha_n$
A	3°
B	5°
C	7°
D	15°
E	20°
F	25°
G	30°
<b>N</b>	0°
P	11°
Z	Sonder Special
MO	Rundwende- platte metrisch Round insert metric
OO	Rundwende- platte Zoll Round insert Inch

**S**  
Schneiden-  
ausführung<sup>1)</sup>  
Cutting edge type<sup>1)</sup>

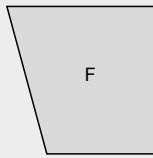

scharfkantig  
sharp-edged

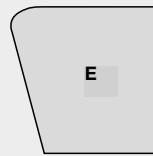

gerundet  
rounded

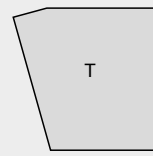

gefast  
chamfered

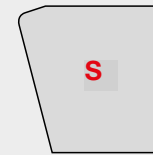

gefast und  
gerundet  
chamfered and  
rounded

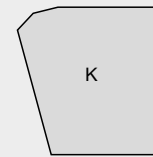

doppelgefast  
double chamfered

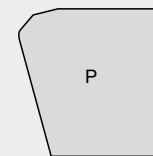

doppelgefast und  
gerundet  
double chamfered  
and rounded

**N**  
Schneidrichtung<sup>1)</sup>  
Direction of cut<sup>1)</sup>

**R**

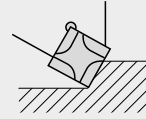

nur rechtsschneidend  
right hand cut only

**L**

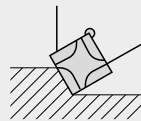

nur linksschneidend  
left hand cut only

**N**



rechts- und links-  
schneidend  
right and left hand cut

<sup>1)</sup>Die Anwendung  
dieser Kennbuch-  
staben ist  
freigestellt.  
The use of these  
reference letters is  
optional

**- MP**  
Boehlerit-Norm  
Boehlerit-Standard

<b>MP</b>	Geometrie für mittlere Stahlbearbeitung Geometry for medium steel machining
MPH	Hochvorschub, f. mittlere Stahlbearbeitung High feed geometry for medium steel machining
RP	Geometrie für Schruppbearbeitung - Stahl Geometry for roughing of steel
RPH	Hochvorschub, für Schruppbearbeitung - Stahl High feed geometry for roughing of steel
RPV	Geom. für schruppen Bearb. Stahl mit Spanteller Geometry for roughing of steel with chip breaker
MM	Geometrie für mittlere Bearb. Rostfrei Geometry for medium stainless machining
MMH	Hochvorschub Geometrie für mittlere Bearb. Rostfrei High feed geometry for medium stainless machining
MK	Geometrie für mittlere Gussbearbeitung Geometry for medium cast iron machining
RK	Geometrie für Schruppbearbeitung Guss Geometry for roughing of cast iron
RKH	Hochvorschub Geometrie für mittlere Bearb. Guss High feed geometry for medium roughing of cast iron
FW	Geometrie für Breitschichten (Wiper) Geometry for wide finishing (Wiper)
ALC	Geometrie für Aluminium Geometry for aluminium
BP	Geometrie für Bearbeitung Stahl Geometry for steel machining
BM	Geometrie für Bearbeitung rostfrei Geometry for stainless machining

**Beispiel:**

	S	N	M	X	12	06	AN	S	N-MP	
	1	2	3	4	5	6	7	8	9	10
1 Grundform	quadratisch									
2 Freiwinkel	0°									
3 Toleranzen	m ± 0,013 s ± 0,025 d ± 0,13									
4 Befestigung Spanfläche	mit Besonderheit nach Zeichnung									
5 Schneidenecke	12,7									
6 Dicke	5,56									
7 Schneidenecke	45° Fase									
8 Schneidenecke	gerundet									
9 Schneidrichtung	rechts- und linksschneidend									
10 Interne Bezeichnung	TR = Spanflächen- topographie									
<b>Example:</b>										
1 Basic form	square									
2 Clearance angle	0°									
3 Tolerances	m ± 0.013 s ± 0.025 d ± 0.13									
4 Fixing cutting face	with special feature according to drawing									
5 Length of cutting edge	12.7									
6 Thickness	5.56									
7 Cutting edge corner	45° chamfer									
8 Cutting edge	rounded									
9 Direction of cut	right- and lefthand									
10 Internal designation	TR = Geometry									

Wendeschneidplattenbezeichnung  
Indexable insert designation  
ISO 1832.2 DIN 4987

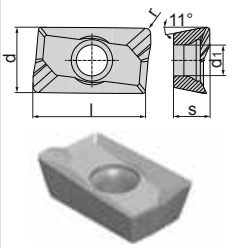
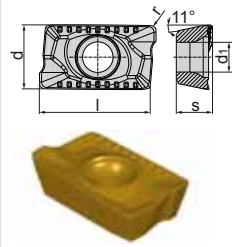
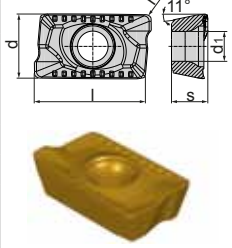
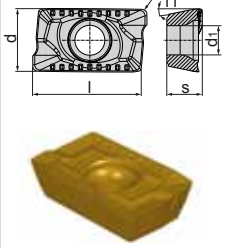
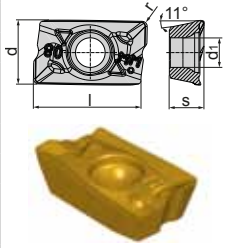
N = Anzahl der Schneidkanten N = Number of cutting edges	Bestellbezeichnung Ordering code	l	d	s	d <sub>1</sub>	r	Schneidstoffsorten Cutting materials										Zuordnung Werkzeuge Assignment tools				
							BCP20M	BCP25M	BCP30M	BCP35M	BCP40M	BCM35M	BCM40M	BCK15M	BCK20M	BCN10M		BWN10M			
 N = 2	APHT 1003 PDFR-ALC	10	6,7	3,5	2,8	0,5															
	APHT 1604 PDFR-ALC	16	9,52	5,26	4,5	0,8															
 N = 2	APKT 1003 PDSR-BP	10	6,7	3,5	2,8	0,5		●	●	●										Seite 42 - 45 Page 42 - 45	
	APKT 1003 PDSR-BM	10	6,7	3,5	2,8	0,5						●	●								
	APKT 1604 PDSR-BP	16	9,52	5,26	4,5	0,8		●	●	●											
	APKT 1604 PDSR-BM	16	9,52	5,26	4,5	0,8						●	●								
 N = 2	APKT 160416 SR-BP	16	9,52	5,26	4,5	1,6				●										Seite 42 - 45 Page 42 - 45	
	APKT 160424 SR-BP	16	9,52	5,26	4,5	2,4				●											
	APKT 160432 SR-BP	16	9,52	5,26	4,5	3,2				●											
 N = 2	APKT 15T3 PDTR-BP	15	9,73	4,36	4,5	0,8				●	●										
 N = 2	APKT 100304 SR-MP2	10	6,7	3,5	2,8	0,4		●		●										Seite 42 - 45 Page 42 - 45	
	APKT 100304 SR-MM2	10	6,7	3,5	2,8	0,4						●									
	APKT 100304 SR-RP2	10	6,7	3,5	2,8	0,4					●										
	APKT 100304 SR-RK2	10	6,7	3,5	2,8	0,4									●						
	APKT 160408 SR-MP2	16	9,52	5,26	4,5	0,8		●		●											
	APKT 160408 SR-MM2	16	9,52	5,26	4,5	0,8							●								
	APKT 160408 SR-RP2	16	9,52	5,26	4,5	0,8					●										
	APKT 160408 SR-RK2	16	9,52	5,26	4,5	0,8									●						

Bestellbeispiel Order example: 10 Stück Pieces APHT 1003 PDFR-ALC BCN10M

● Verfügbar ab Lager Available from stock

Sortenbeschreibung Seite 8-9  
Description of grades page 8-9

Farbliche Abbildung der WSP müssen nicht dem Original entsprechen!  
Colours of the original indexable inserts may deviate from the illustration!

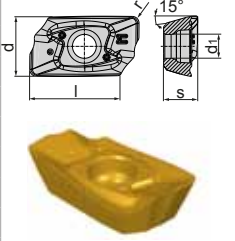
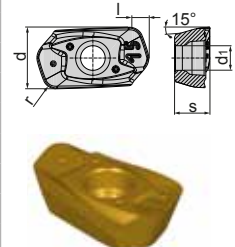
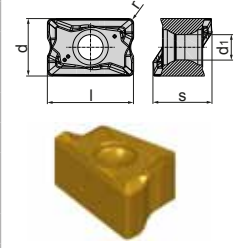
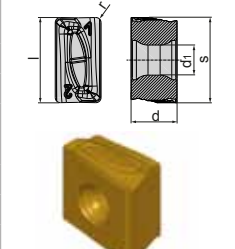
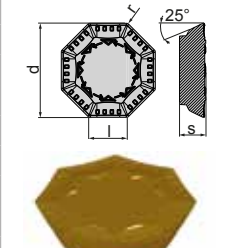
N = Anzahl der Schneidkanten N = Number of cutting edges	Bestellbezeichnung Ordering code	l	d	s	d <sub>1</sub>	r	Schneidstoffsorten Cutting materials										Zuordnung Werkzeuge Assignment tools				
							BCP20M	BCP25M	BCP30M	BCP35M	BCP40M	BCM35M	BCM40M	BCK15M	BCK20M	BCN10M		BWN10M			
 N = 2	LDMX 100408 SR-MP	10	6,6	4,76	2,8	0,8		●													
	LDMX 100408 ER-MM	10	6,6	4,76	2,8	0,8							●								
	LDMX 100408 SR-MK	10	6,6	4,76	2,8	0,8									●						
 N = 2	LDMX 100415 SR-MPH	1,5	6,6	4,76	2,8	1,5		●													
	LDMX 100415 ER-MMH	1,5	6,6	4,76	2,8	1,5							●								
 N = 4	LNMX 100605 SR-RP	10	6,6	6,35	2,8	0,5		●													
	LNMX 100605 SR-RK	10	6,6	6,35	2,8	0,5															●
	LNMX 151008 SR-RP	15	9,52	10,0	4,5	0,8		●													
	LNMX 151008 SR-RK	15	9,52	10,0	4,5	0,8															●
 N = 4	LNMX 131308 SR-RP	13	7,94	13	4,6	0,8															
	LNMX 131308 SR-RK	13	7,94	13	4,6	0,8															●
 N=8	OFER 070405 SN-BP	7	18,1	4,76	-	0,5		●													

Bestellbeispiel Order example: 10 Stück Pieces LDMX 100408 SR-MP BCP25M

● Verfügbar ab Lager Available from stock

Sortenbeschreibung Seite 8-9  
Description of grades page 8-9

Farbliche Abbildung der WSP müssen nicht dem Original entsprechen!  
Colours of the original indexable inserts may deviate from the illustration!

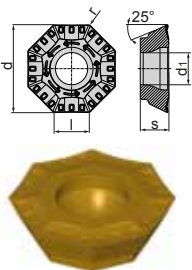
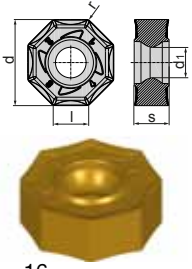
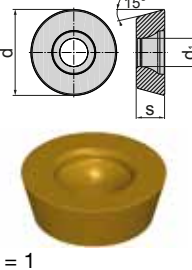
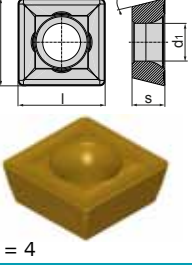
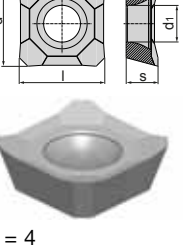
N = Anzahl der Schneidkanten N = Number of cutting edges	Bestellbezeichnung Ordering code	l	d	s	d <sub>1</sub>	r	Schneidstoffsorten Cutting materials								Zuordnung Werkzeuge Assignment tools				
							BCP20M	BCP25M	BCP30M	BCP35M	BCP40M	BCM35M	BCM40M	BCK15M		BCK20M	BCN10M	BWN10M	
 N = 8	OFEX 05T305 SN-BP	5	12,7	3,97	4,6	0,5		●	●	●									
 N = 16	ONMU 080608 SN-MP	8	19	6,95	6,75	0,8		●	●	●									
	ONMU 080608 SN-MM	8	19	6,95	6,75	0,8					●	●							
	ONMU 080608 SN-MK	8	19	6,95	6,75	0,8							●	●					
	ONMQ 0806-FW	8	19,1	6,95	6,75	-					●								
 N = 1	RDKW 1003 MOS	10	10	3,18	3,9		●	●	●	●			●	●					
	RDKW 12T3 MOS	12	12	3,97	3,9		●	●	●	●			●	●					
	RDKW 1604 MOS	16	16	4,67	5,2		●	●	●	●			●	●					
 N = 4	SCMX 120512	12,70	12,70	5,56	5,5	1,2			●										
 N = 4	SDHT 1204 AEFN-ALC	12,70	12,70	4,76	5,5	-										●	●		
	SDHT 1504 AEFN-ALC	15,88	15,88	4,76	5,5	-												●	

Seite 22 - 23  
Page 22 - 23

Bestellbeispiel Order example: 10 Stück Pieces OFEX 05T305 SN-BP BCP25M

● Verfügbar ab Lager Available from stock

Sortenbeschreibung Seite 8-9  
Description of grades page 8-9

Farbliche Abbildung der WSP müssen nicht dem Original entsprechen!  
Colours of the original indexable inserts may deviate from the illustration!

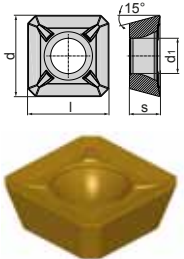
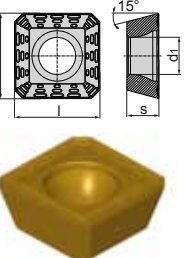
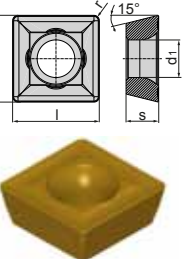
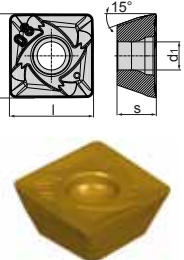
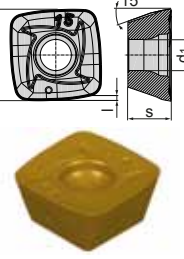

N = Anzahl der Schneidkanten N = Number of cutting edges	Bestellbezeichnung Ordering code	l	d	s	d <sub>1</sub>	r	Schneidstoffsorten Cutting materials										Zuordnung Werkzeuge Assignment tools					
							BCP20M	BCP25M	BCP30M	BCP35M	BCP40M	BCM35M	BCM40M	BCK15M	BCK20M	BCN10M		BWN10M				
 N = 4	SDHT 1204 AESN	12,70	12,70	4,76	5,5			●	●	●												
	SDHT 1504 AESN	15,88	15,88	4,76	5,5					●												
 N = 4	SDHT 1204 AESN-BM	12,70	12,70	4,76	5,5								●									
 N = 4	SDMT 090308	9,52	9,52	3,18	4	0,8		●														
	SDMT 120408-SN	12,70	12,70	4,76	5,5	0,8			●													
	SDMT 1205 PDSR-BP	12,70	12,70	5,56	5,5	-				●	●											
 N = 4	SDMT 100408 SR-MP	10,4	10,4	4,86	3,5	0,8				●												
	SDMT 100408 ER-MM	10,4	10,4	4,86	3,5	0,8						●										
	SDMT 100408 SR-MK	10,4	10,4	4,86	3,5	0,8								●								
	SDMT 140512 SR-MP	14,8	14,8	5,2	5,5	1,2				●												
	SDMT 140512 ER-MM	14,8	14,8	5,2	5,5	1,2						●										
	SDMT 140512 SR-MK	14,8	14,8	5,2	5,5	1,2								●								
 N = 4	SDMT 100415 SR-MPH	1,1	10,2	4,76	3,5	1,5		●	●													
	SDMT 100415 ER-MMH	1,1	10,2	4,76	3,5	1,5						●										
	SDMT 140520 SR-MPH	2,2	14,7	5	5,5	2		●	●													
	SDMT 140520 ER-MMH	2,2	14,7	5	5,5	2						●										

Bestellbeispiel Order example: 10 Stück Pieces SDHT 1204 AESN BCP35M

● Verfügbar ab Lager Available from stock

Sortenbeschreibung Seite 8-9  
Description of grades page 8-9

Farbliche Abbildung der WSP müssen nicht dem Original entsprechen!  
Colours of the original indexable inserts may deviate from the illustration!

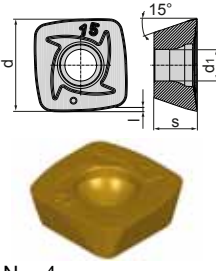
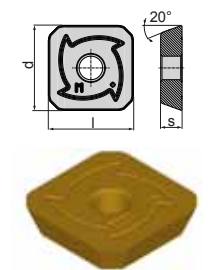
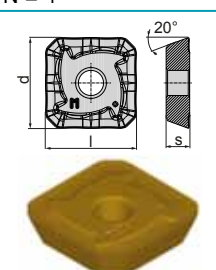
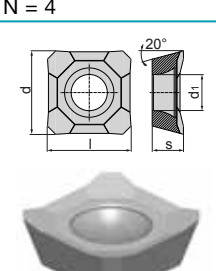
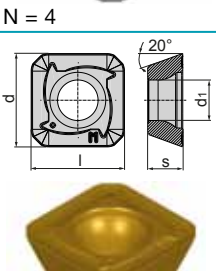
N = Anzahl der Schneidkanten N = Number of cutting edges	Bestellbezeichnung Ordering code	l	d	s	d <sub>1</sub>	r	Schneidstoffsorten Cutting materials										Zuordnung Werkzeuge Assignment tools
							BCP20M	BCP25M	BCP30M	BCP35M	BCP40M	BCM35M	BCM40M	BCK15M	BCK20M	BCN10M	
 N = 4	SDMW 100415 SR-RPH	1,1	10,2	4,76	3,5	1,5			●	●							
	SDMW 100415 SR-RKH	1,1	10,2	4,76	3,5	1,5							●	●			
	SDMW 140520 SR-RPH	2,2	14,7	5	5,5	2			●	●							
	SDMW 140520 SR-RKH	2,2	14,7	5	5,5	2							●	●			
 N = 4	SEKN 1203 AFSN-MP	12,70	12,70	3,18	-	-		●	●	●							
	SEKN 1203 AFEN-MM	12,70	12,70	3,18	-	-						●					
	SEKN 1203 AFSN-MK	12,70	12,70	3,18	-	-							●	●			
	SEKN 1504 AFSN-MP	15,88	15,88	4,76	-	-		●	●	●							
	SEKN 1504 AFEN-MM	15,88	15,88	4,76	-	-						●					
 N = 4	SEKR 1203 AFSN-MP	12,70	12,70	3,18	-	-		●	●	●							
 N = 4	SEHT 1204 AFFN-ALC	12,70	12,70	4,76	5,5	-									●	●	
	SEKT 1204 AFSN-MP	12,70	12,70	4,76	5,5	-	●	●	●	●							
 N = 4	SEKT 1204 AFEN-MM	12,70	12,70	4,76	5,5	-						●					

Bestellbeispiel Order example: 10 Stück Pieces SDMW 100415 SR-RKH BCK15M

● Verfügbar ab Lager Available from stock

Sortenbeschreibung Seite 8-9  
Description of grades page 8-9

Farbliche Abbildung der WSP müssen nicht dem Original entsprechen!  
Colours of the original indexable inserts may deviate from the illustration!

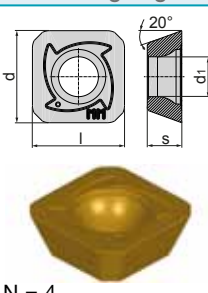
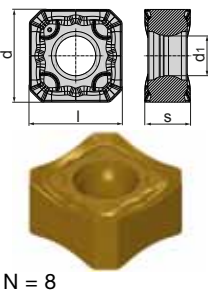
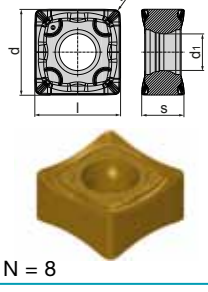
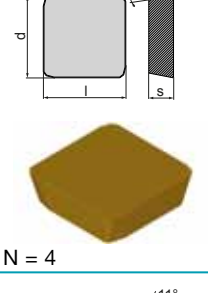
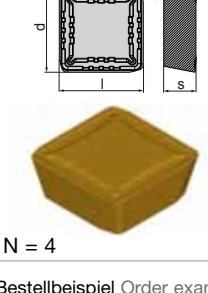
N = Anzahl der Schneidkanten N = Number of cutting edges	Bestellbezeichnung Ordering code	l	d	s	d <sub>1</sub>	r	Schneidstoffsorten Cutting materials										Zuordnung Werkzeuge Assignment tools	
							BCP20M	BCP25M	BCP30M	BCP35M	BCP40M	BCM35M	BCM40M	BCK15M	BCK20M	BCN10M		BWN10M
 N = 4	SEKW 1204 AFSN-MP	12,70	12,70	4,76	5,5	-		●	●	●								
	SEKW 1204 AFEN-MM	12,70	12,70	4,76	5,5	-							●					
	SEKW 1204 AFSN-MK	12,70	12,70	4,76	5,5	-								●	●			
 N = 8	SNMX 1206 ANSN-MP	12,70	12,70	6,35	5,2	-		●	●	●								
	SNMX 1206 ANSN-MM	12,70	12,70	6,35	5,2	-						●	●					
	SNMX 1206 ANSN-MK	12,70	12,70	6,35	5,2	-								●	●			
	SNEX 1206-FW	12,70	12,70	6,35	5,2	-						●						
 N = 8	SNMX 120608 SN-MP	12,70	12,70	6,35	5,2	0,8			●	●								
	SNMX 120608 SN-MM	12,70	12,70	6,35	5,2	0,8						●						
	SNMX 120608 SN-MK	12,70	12,70	6,35	5,2	0,8							●	●				
	SNMX 120612 SN-MP	12,70	12,70	6,35	5,2	1,2			●	●								
	SNMX 120612 SN-MK	12,70	12,70	6,35	5,2	1,2								●	●			
 N = 4	SPKN 1203 EDSR	12,70	12,70	3,18	-	-		●	●					●				
	SPKN 1504 EDSR	15,88	15,88	4,76	-	-		●	●									
 N = 4	SPKR 1203 EDSR	12,70	12,70	3,18	-	-			●									

Bestellbeispiel Order example: 10 Stück Pieces SEKW 1204 AFSN-MP BCP30M

● Verfügbar ab Lager Available from stock

Sortenbeschreibung Seite 8-9  
Description of grades page 8-9

Farbliche Abbildung der WSP müssen nicht dem Original entsprechen!  
Colours of the original indexable inserts may deviate from the illustration!

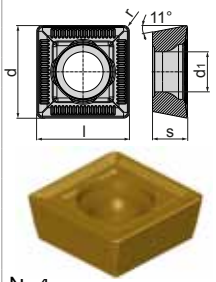
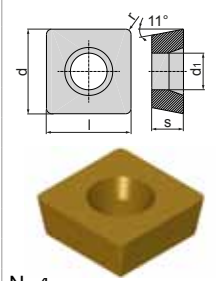
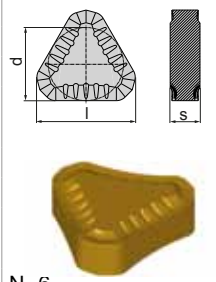
N = Anzahl der Schneidkanten N = Number of cutting edges	Bestellbezeichnung Ordering code	l	d	s	d <sub>1</sub>	r	Schneidstoffsorten Cutting materials										Zuordnung Werkzeuge Assignment tools			
							BCP20M	BCP25M	BCP30M	BCP35M	BCP40M	BCM35M	BCM40M	BCK15M	BCK20M	BCN10M		BWN10M		
	SPMT 060304	6,35	6,35	3,2	3,4	0,4			●											
	SPMT 120408-SN	12,70	12,70	4,76	5,2	0,8			●	●										
	SPMW 120408	12,70	12,70	4,76	5,2	0,8							●							
	TNHF 1204 ANSN-BK	12	12,70	4,76	-	-									●					
	TPKN 1603 PDSR	16,5	9,52	3,18	-	-		●	●											
	TPKN 1603 PDER	16,5	9,52	3,18	-	-							●							
	TPKN 2204 PDSR	22	12,70	4,76	-	-		●	●											
	TPKN 2204 PDER	22	12,70	4,76	-	-							●							

Bestellbeispiel Order example: 10 Stück Pieces SPMT 060304 BCP30M

● Verfügbar ab Lager Available from stock

Sortenbeschreibung Seite 8-9  
Description of grades page 8-9

Farbliche Abbildung der WSP müssen nicht dem Original entsprechen!  
Colours of the original indexable inserts may deviate from the illustration!

Fräsen 45°

Milling 45°

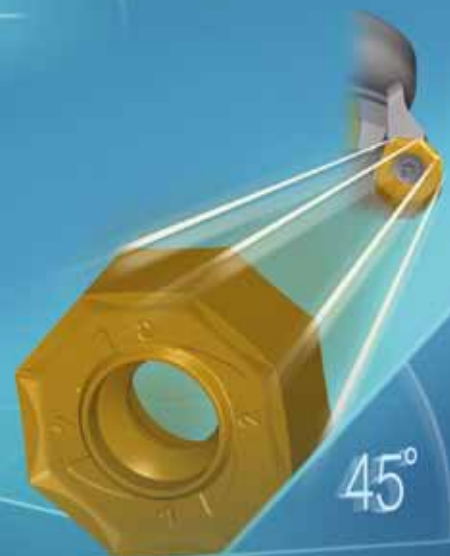
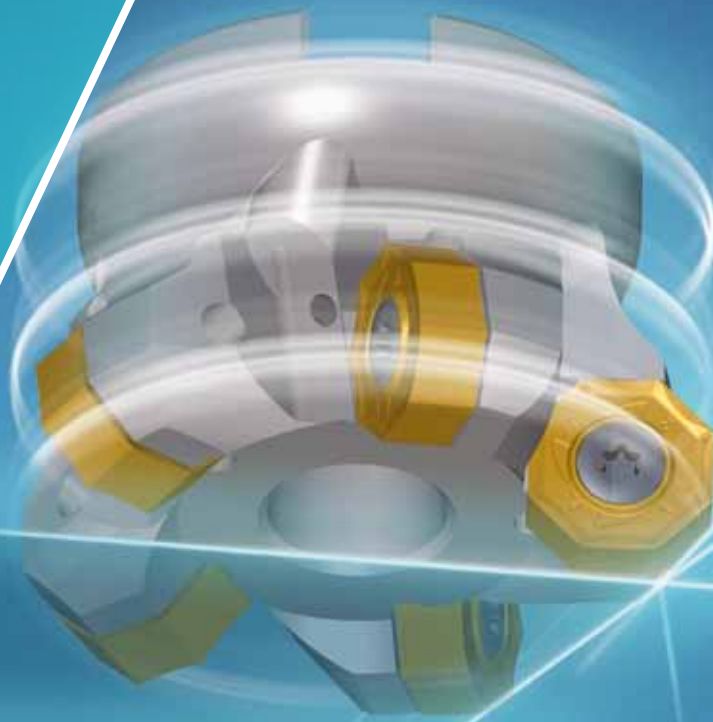

**Ø 50 - 160**  
**Aufsteckfräser**  
**Face Milling Cutter**  
**Plattengröße 08**  
**Insert size 08**

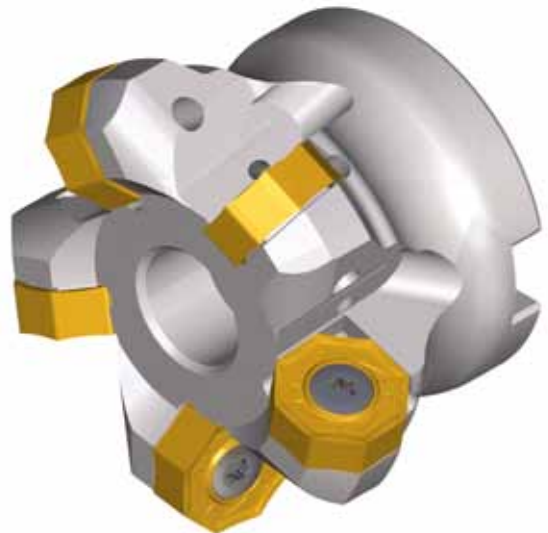

### Besondere Merkmale:

- 16 Schneidkanten zur Produktivitätssteigerung
- Negative Grundgeometrie dadurch extrem stabil
- Effektiv positive Schneidkanten­geometrie, dadurch leichter Schnitt
- Nummerierung der Schneiden für exakten Rundlauf
- WIPER - Geometrie für qualitativ hochwertige Oberfläche. Beste Ergebnisse bei Erhöhung der Schnittgeschwindigkeit (ca. doppelte  $v_c$ , niedriger Schnitttiefe, ca.  $a_p$  0,7 mm Zahnvorschub, ca.  $f_z$  0,25 mm bei Fräserdurchmesser 63 mm)
- Hohes Zerspanvolumen durch enge Teilung der Werkzeuge
- Ungleichteilung führt zu Schwingungsreduktion und extremer Laufruhe
- Schneidstoffvielfalt für optimale Zerspanungsergebnisse auf einem breiten Materialspektrum

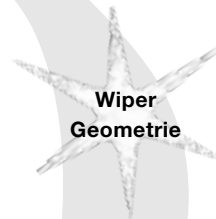

Wiper Geometrie



ONMQ 0806-FW

### Special features:

- 16 cutting edges for increase of productivity
- negativ basic geometry, thus extremely stable
- effective positive cutting edge geometry, thus smooth cut
- numbering of cutting edges for exact true running
- BCM35M in combination
- WIPER – geometry for qualitativ high-class surface. Best results if increasing cutting speed (appr. double  $v_c$  small cutting depth, appr.  $a_p$  0.7 mm tooth feed, appr.  $f_z$  0.25 mm with milling cutter diameter 63 mm)
- big metal removal due to close division of the tools
- uneven spacing leads to reduced vibration and extremely smooth running
- cutting material diversity for optimal cutting results on a wide range material

WSP Geometrie Insert geometry	Schnitttiefe Cutting depth [ mm ] $a_p$ max	Vorschub Feed [ mm ] $f_z$
MP	1 2,5 4	0,15 0,25 0,35
MM	1 2,5 4	0,15 0,22 0,30
MK	1 2,5 4	0,15 0,27 0,40
FW	0,5 0,7 0,9	0,2 0,25 0,30

Optimale Schnittwerte aus Tabelle ersichtlich!  
Optimal cutting data see chart!

Schnittgeschwindigkeit Seite 28  
Cutting speed page 28

### Aufsteckfräser 45° für ONMU... Face milling cutter 45° for ONMU...

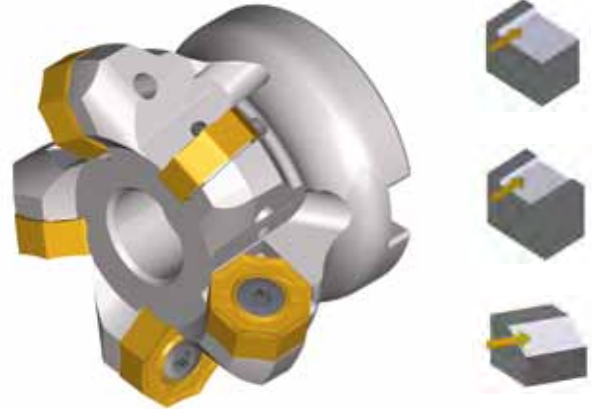
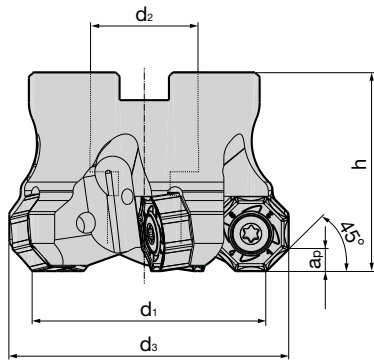

Abmessungen in mm Dimensions in mm						Bestellbezeichnung Ordering code	Verfügbarkeit Availability	Ersatzteile Spare parts	
d <sub>1</sub>	d <sub>3</sub>	h	d <sub>2</sub>	a <sub>p</sub>	z			Spann- schraube Fixation screw A02-60150 5085705	Torx- Schlüssel Torque wrench T25 5088518
50	60	50	22	5	4	<b>BF45 ON08.050 Z04</b>	●		
63	73	50	27	5	5	<b>BF45 ON08.063 Z05</b>	●		
80	90	50	32	5	6	<b>BF45 ON08.080 Z06</b>	●		
80	90	50	32	5	7	<b>BF45 ON08.080 Z07</b>	●		
100	110	50	32	5	7	<b>BF45 ON08.100 Z07</b>	●		
100	110	50	32	5	9	<b>BF45 ON08.100 Z09</b>	●		
125	135	63	40	5	9	<b>BF45 ON08.125 Z09</b>	●		
125	135	63	40	5	11	<b>BF45 ON08.125 Z11</b>	●		
160	170	63	40	5	11	<b>BF45 ON08.160 Z11</b>	●		

Bestellbeispiel Order example: 1 Stück Piece BF45 ON08.050 Z04

N = Anzahl der Schneidkanten N = Number of cutting edges	Bestellbezeichnung Ordering code	l	d	s	d <sub>1</sub>	r	Schneidstoffsorten Cutting materials Ident No.											
							BCP20M	BCP25M	BCP30M	BCP35M	BCP40M	BCM35M	BCM40M	BCK15M	BCK20M	BCN10M	BWN10M	
								<b>ONMU 080608 SN-MP</b>	8	19	6,95	6,75	0,8	●	●	●		
	<b>ONMU 080608 SN-MM</b>	8	19	6,95	6,75	0,8					●	●						
	<b>ONMU 080608 SN-MK</b>	8	19	6,95	6,75	0,8							●	●				
	<b>ONMQ 0806-FW</b>	8	19,1	6,95	6,75	0,8					●							

Bestellbeispiel Order example: 10 Stück Pieces ONMU 080608 SN-MP BCP25M

● Verfügbar ab Lager Available from stock

Sortenbeschreibung Seite 8-9  
Description of grades page 8-9

**Ø 50 - 250**  
**Aufsteckfräser**  
**Face Milling Cutter**  
**Plattengröße 12**  
**Insert size 12**



### Besondere Merkmale:

- 8 Schneidkanten zur Produktivitätssteigerung bei hohen Schnitttiefen
- Negative Grundgeometrie dadurch extrem stabil
- Effektiv positive Schneidkanten-geometrie, dadurch leichter Schnitt
- Markierung der Schneiden für exakten Rundlauf
- WIPER - Geometrie für qualitativ hochwertige Oberfläche
- Hohes Zerspanvolumen, durch enge und sehr enge Teilung der Werkzeuge
- Ungleichteilung führt zu Schwingungsreduktion und zu extremer Laufruhe
- Schneidstoffvielfalt für optimale Zerspanungsergebnisse auf einem breiten Materialspektrum

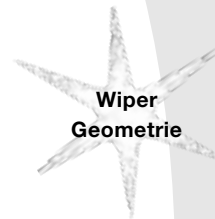

Wiper  
Geometrie

**SNEX 1206-FW**

### Special features:

- 8 cutting edges for increase of productivity with big cutting depths
- negative basic geometry, therefore extremely stable
- effective positive cutting edge geometry, therefore smooth cut
- marking of the cutting edges for exact concentricity
- WIPER geometry for qualitativ high-class surface
- high metal removal, due to narrow and very narrow partition of the tools
- uneven spacing leads to reduced vibration and extremely smooth running
- diversity of cutting materials for optimal cutting results on a wide material range

WSP Geometrie Insert geometry	Schnitttiefe Cutting depth [ mm ] $a_p$ max	Vorschub Feed [ mm ] $f_z$
MP	1 4 6	0,18 <b>0,26</b> 0,35
MM	1 4 6	0,15 <b>0,23</b> 0,28
MK	1 4 6	0,20 <b>0,3</b> 0,40
FW	0,2 <b>0,5</b> 0,7	0,15 <b>0,27</b> 0,40

Optimale Schnittwerte aus Tabelle ersichtlich!  
Optimal cutting data see chart!

Schnittgeschwindigkeit Seite 28  
Cutting speed page 28



**Aufsteckfräser 45° für SNMX...**  
Face milling cutter 45° for SNMX..

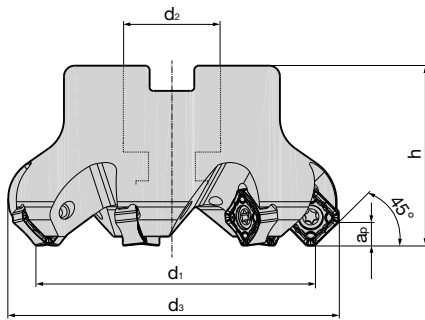

Abmessungen in mm Dimensions in mm						Bestellbezeichnung Ordering code	Verfügbarkeit Availability	Ersatzteile Spare parts	
d <sub>1</sub>	d <sub>3</sub>	h	d <sub>2</sub>	a <sub>p</sub>	z			Spannschraube Fixation screw A06-40115 5084080	Torx-Schlüssel Torque wrench T15 5088516
50	63,4	40	22	6,5	4	<b>BF45 SN12.050 Z04</b>	●		
50	63,4	40	22	6,5	6	<b>BF45 SN12.050 Z06</b>	●		
63	76,4	40	22	6,5	6	<b>BF45 SN12.063 Z06</b>	●		
63	76,4	40	22	6,5	8	<b>BF45 SN12.063 Z08</b>	●		
80	93,4	50	27	6,5	7	<b>BF45 SN12.080 Z07</b>	●		
80	93,4	50	27	6,5	10	<b>BF45 SN12.080 Z10</b>	●		
100	113,4	50	32	6,5	8	<b>BF45 SN12.100 Z08</b>	●		
100	113,4	50	32	6,5	12	<b>BF45 SN12.100 Z12</b>	●		
125	138,4	63	40	6,5	10	<b>BF45 SN12.125 Z10</b>	●		
125	138,4	63	40	6,5	16	<b>BF45 SN12.125 Z16</b>	●		
160	173,4	63	40	6,5	12	<b>BF45 SN12.160 Z12</b>	●		
160	173,4	63	40	6,5	20	<b>BF45 SN12.160 Z20 NC</b>	○		
200	213,4	63	40	6,5	18	<b>BF45 SN12.200 Z18</b>	●		
200	213,4	63	40	6,5	26	<b>BF45 SN12.200 Z26 NC</b>	○		
250	263,4	63	40	6,5	20	<b>BF45 SN12.250 Z20</b>	●		
250	263,4	63	40	6,5	30	<b>BF45 SN12.250 Z30 NC</b>	○		

Bestellbeispiel Order example: 1 Stück Piece BF45 SN12.050 Z04

N = Anzahl der Schneidkanten N = Number of cutting edges	Bestellbezeichnung Ordering code	l	d	s	d <sub>1</sub>	r	Schneidstoffsorten Cutting materials Ident No.												
							BCP20M	BCP25M	BCP30M	BCP35M	BCP40M	BCM35M	BCM40M	BCK15M	BCK20M	BCN10M	BWN10M		
  N = 8	<b>SNMX 1206 ANSN-MP</b>	12,70	12,70	6,35	5,2	-	●	●	●										
	<b>SNMX 1206 ANSN-MM</b>	12,70	12,70	6,35	5,2	-					●	●							
	<b>SNMX 1206 ANSN-MK</b>	12,70	12,70	6,35	5,2	-								●	●				
	<b>SNEX 1206-FW</b>	12,70	12,70	6,35	5,2							●							

Bestellbeispiel Order example: 10 Stück Pieces SNMX 1206 ANSN-MP BCP25M

● Verfügbar ab Lager Available from stock  
○ Verfügbar auf Anfrage Available on request

Sortenbeschreibung Seite 8-9  
Description of grades page 8-9

**Ø 40 - 125**  
**Aufsteckfräser**  
**Face Milling Cutter**  
**Plattengröße 12**  
**Insert size 12**

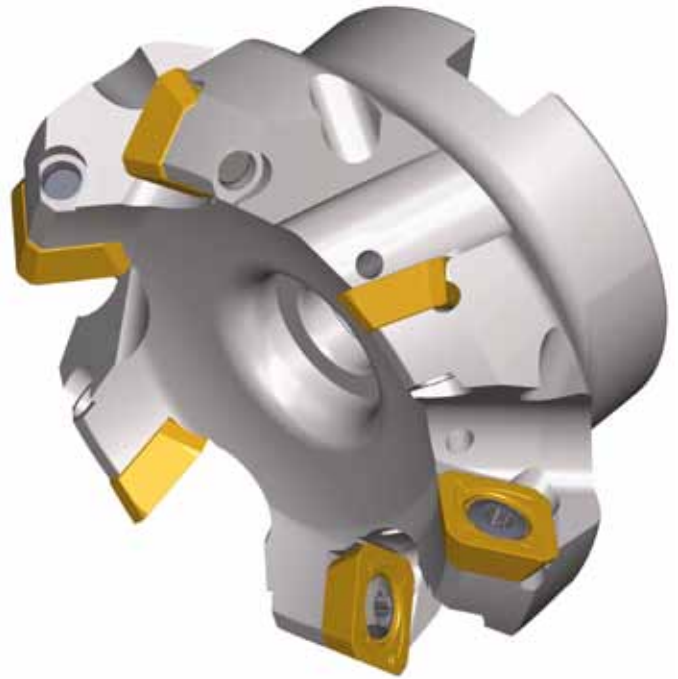

#### Besondere Merkmale:

- Positive Grundgeometrie dadurch leicht schneidend
- 4 Schneidkanten zur Produktivitätssteigerung
- Markierung der Schneiden für exakten Rundlauf
- durch die geringe Leistungsaufnahme, hohes Zerspanvolumen, auch auf leistungsschwachen alten Maschinen
- Ungleichteilung führt zu Schwingungsreduktion und extremer Laufruhe
- Schneidstoffvielfalt für optimale Zerspanungsergebnisse auf einem breiten Materialspektrum

#### Special features:



- positive basic geometry, therefore easy cutting
- 4 cutting edges for increase of productivity
- marking of the cutting edges for exact concentricity
- high metal removal also on inefficient old machines due to small performance
- uneven spacing leads to reduced vibration and extremely smooth running
- diversity of cutting materials for optimal cutting results on a wide material range



WSP Geometrie Insert geometry	Schnitttiefe Cutting depth [ mm ] $a_p$ max	Vorschub Feed [ mm ] $f_z$
MP	1 4 6	0,16 <b>0,25</b> 0,35
MM	1 4 6	0,10 <b>0,2</b> 0,30
MK	1 4 6	0,18 <b>0,3</b> 0,40
ALC	0,7 <b>3,3</b> 6	0,08 <b>0,18</b> 0,28

Optimale Schnittwerte aus Tabelle ersichtlich!  
Optimal cutting data see chart!

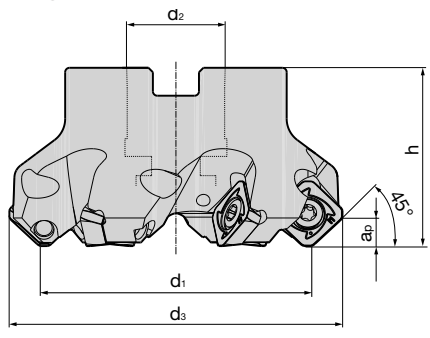
Schnittgeschwindigkeit Seite 28  
Cutting speed page 28

**Aufsteckfräser 45° für SE...**  
**Face milling cutter 45° for SE...**

Abmessungen in mm Dimensions in mm						Bestellbezeichnung Ordering code	Verfügbarkeit Availability	Ersatzteile Spare parts	
d <sub>1</sub>	d <sub>3</sub>	h	d <sub>2</sub>	a <sub>p</sub>	z				
40	53	40	16	6	4	<b>BF45 SE12.040 Z04</b>	●	 Spannschraube Fixation screw AP13-45108 5085713	 Torx-Schlüssel Torque wrench 20IP 5088521
50	63	40	22	6	5	<b>BF45 SE12.050 Z05</b>	●		
63	76	50	22	6	6	<b>BF45 SE12.063 Z06</b>	●		
80	93	50	27	6	7	<b>BF45 SE12.080 Z07</b>	●		
100	113	50	32	6	8	<b>BF45 SE12.100 Z08</b>	●		
125	138	63	40	6	10	<b>BF45 SE12.125 Z10</b>	●		

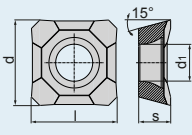
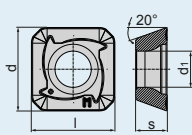
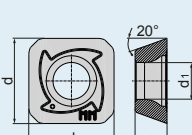

Bestellbeispiel Order Example: 1 Stück Piece BF45 SE12.040 Z04

N = Anzahl der Schneidkanten N = Number of cutting edges	Bestellbezeichnung Ordering code	l	d	s	d <sub>1</sub>	r	Schneidstoffsorten Cutting materials Ident No.												
							BCP20M	BCP25M	BCP30M	BCP35M	BCP40M	BCM35M	BCM40M	BCK15M	BCK20M	BCN10M	BWN10M		
 N = 4	<b>SEHT 1204 AFFN-ALC</b>	12,70	12,70	4,76	5,5	-												●	●
 N = 4	<b>SEKT 1204 AFSN-MP</b>	12,70	12,70	4,76	5,5	-	●	●	●	●									
	<b>SEKT 1204 AFEN-MM</b>	12,70	12,70	4,76	5,5	-						●							
 N = 4	<b>SEKW 1204 AFEN-MP</b>	12,70	12,70	4,76	5,5	-		●	●	●									
	<b>SEKW 1204 AFSN-MM</b>	12,70	12,70	4,76	5,5	-						●							
	<b>SEKW 1204 AFSN-MK</b>	12,70	12,70	4,76	5,5	-								●	●				

Bestellbeispiel Order example: 10 Stück Pieces SEHT 1204 AFFN-ALC BCN10M

● Verfügbar ab Lager Available from stock

Sortenbeschreibung Seite 8-9  
 Description of grades page 8-9

Werkstoff-Gruppe Material group	WSP -Sorte Insert grade				BCP20M	BCP25M	BCP30M
	ISO Code		Trockenbe- arbeitung Dry machining	Nassbe- arbeitung Wet machining	P20	P25	P30
	Werkstoff Material						
<b>P</b>	Baustahl Structural steel		●	○	190 - 290	175 - 265	160 - 240
	Vergütungsstahl Heat treated steel		●	○	160 - 230	145 - 215	140 - 190
	Werkzeugstahl Tool steel		●	○	145 - 210	130 - 190	120 - 175
	Gehärteter Stahl Hardened steel		●	○	110 - 170		100 - 160
<b>M</b>	Nichtrostender Stahl Stainless steel	austenitisch austenitic	●	○		90 - 150	
		austenitisch gehärtet austenitic hardened	●	○		60 - 110	
<b>K</b>	Grauguss Grey cast iron		●	○		140 - 300	
	Gusseisen mit Kugelgraphit Nodular graphite cast iron		●	○		100 - 160	
<b>N</b>	Aluminium Aluminium		●	○			
	Kupfer und Kupferlegierungen Copper and copper alloys		●	○			
<b>S</b>	Warmfeste Legierungen Heat resistant alloys		○	●			
	Titanlegierungen Titanium alloys		○	●			

- empfohlene Anwendung recommended application
- alternative Anwendung um 30 - 50 % reduzieren  
alternative application by 30 - 50 % reduced

	BCP35M P35	BCP40M P40	BCM35M M35	BCM40M M40	BCK15M K15	BCK20M K20	BWN10M N10	BCN10M N10
	120 - 240	100 - 220				200 - 300		
	145 - 215	145 - 215				180 - 250		
	130 - 190	130 - 190				160 - 220		
						120 - 180		
	80 - 140	70 - 130	110 - 180	100 - 160				
			80 - 130	70 - 120				
					180 - 360	150 - 320		
					140 - 250	110 - 180		
							400 - 2500	500 - 3000
							120 - 400	160 - 500
				30 - 70			25 - 80	
				30 - 80			30 - 80	



**Fräsen 90°**

**Milling 90°**



## Multifunktional Multi Functional

**Ø 40 - 80**  
**Aufsteckfräser**  
 Face Milling Cutter  
 Plattengröße 10  
 Insert size 10

**Ø 16 - 32**  
**Schaftfräser**  
 End Milling Cutter  
 Plattengröße 10  
 Insert size 10

**Ø 16 - 32**  
**Einschraubfräser**  
 Screw on type  
 Plattengröße 10  
 Insert size 10



### Besondere Merkmale: Fräsen 90°

- Multifunktionales Werkzeugsystem für höchste Produktivität
- 1 Grundkörper für 2 Bearbeitungsverfahren = Multifunktional
- Erleichterung der Lagerhaltung und der Werkzeugbeschaffung durch weniger Artikel
- Exakte 90° Schulter bis ca. 1/2 Schneidkantenlänge über alle Durchmesser
- Helixschneidkante für geringe Schnittkräfte
- Schwingungsdämpfendes Konzept für hohe Auskräglängen in Kombination mit VHM-Verlängerungen
- Reduktion der Bearbeitungskosten durch absatzfreies Fräsen
- Hohe Zerspanungsraten auch auf leistungsschwachen Maschinen

### Special features: Milling 90°

- multifunctional tool system for highest productivity
- 1 basic body for 2 machining methods = multi functional
- facilitation of storage and tool procurement through less articles
- exact 90° shoulder up to 1/2 cutting edge length on all diameters
- helix cutting edge for small cutting powers
- vibration damping concept for big blade overhang in combination with solid carbide extensions
- reduction of machining costs due to uninterrupted milling
- high cutting rates also on inefficient machines

WSP Geometrie Insert geometry	Schnitttiefe Cutting depth [ mm ] $a_p$ max	Vorschub Feed [ mm ] $f_z$
MP	1 4 10	0,1 <b>0,2</b> 0,28
MM	1 4 10	0,1 <b>0,18</b> 0,25
MK	1 4 10	0,15 <b>0,25</b> 0,3

Optimale Schnittwerte aus Tabelle ersichtlich!

Optimal cutting data see chart!

Schnittgeschwindigkeit Seite 52

Cutting speed page 52



## Multifunktional Multi Functional

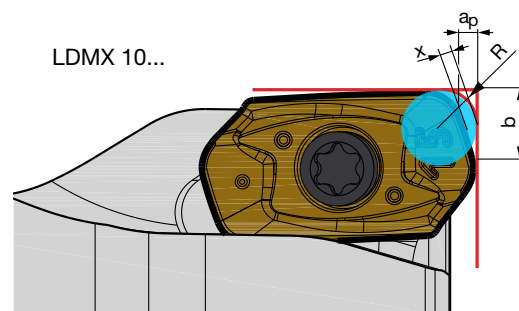
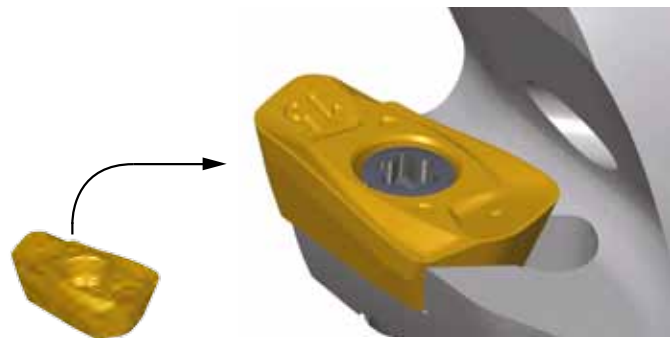
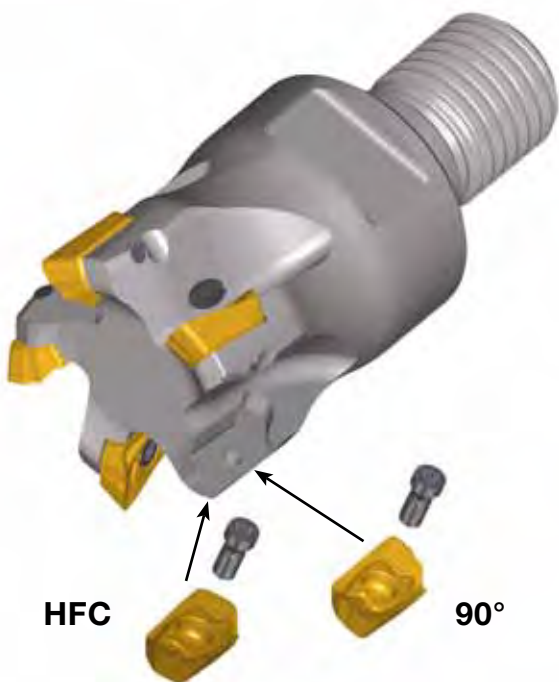

### Besondere Merkmale: Fräsen HFC

- Hohe Zerspanungsraten bei guter Prozesssicherheit
- Leichter Schnitt auch in Vollnuten
- Funktionstauglichkeit der beiden Schneidkanten auch bei der Bearbeitung im "Spanbecken" zu 100 % sichergestellt
- Optimale Schnittkraftverteilung durch spezielle Schneidkantengeometrie

LDM..	R	$a_p$	x	b
10	2,2	1,5	0,4	3,52

### Special features: Milling HFC

- high cutting rates with good process security
- smooth cut also in slot milling
- functionality of both cutting edges guaranteed to 100 % also on machining in the „chip tank“
- optimal distribution of cutting forces due to special cutting edge geometry

WSP Geometrie Insert geometry	Schnitttiefe Cutting depth [ mm ] $a_p$ max	Vorschub Feed [ mm ] $f_z$
MPH	0,4 <b>0,9</b> 1,4	0,6 <b>1</b> 1,5
MMH	0,4 <b>0,9</b> 1,4	0,5 <b>0,9</b> 1,3

Optimale Schnittwerte aus Tabelle ersichtlich!

Optimal cutting data see chart!

Schnittgeschwindigkeit Seite 52

Cutting speed page 52

## Aufsteckfräser 90° / LDMX ... Face milling cutter 90° / LDMX ...

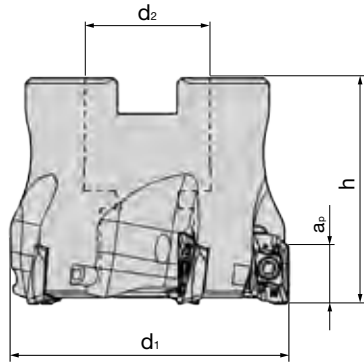

Abmessungen in mm		Dimensions in mm			z	Bestellbezeichnung Ordering code	Verfügbarkeit Availability	Ersatzteile Spare parts	
$d_1$	$d_2$	$h$	$a_{p/90}$	$a_{p/HFC}$				Spann- schraube Fixation screw AP02-25068 5085706	Torx- Schlüssel Torque wrench 8IP 5088519
40	16	40	9	1,5	4	BF90 LD10.040 Z04	●		
40	16	40	9	1,5	6	BF90 LD10.040 Z06	●		
50	22	40	9	1,5	5	BF90 LD10.050 Z05	●		
50	22	40	9	1,5	7	BF90 LD10.050 Z07	●		
63	22	40	9	1,5	6	BF90 LD10.063 Z06	●		
63	22	40	9	1,5	8	BF90 LD10.063 Z08	●		
80	27	50	9	1,5	10	BF90 LD10.080 Z10	●		

## Schaftfräser 90° / LDMX ... End milling cutter 90° / LDMX ...

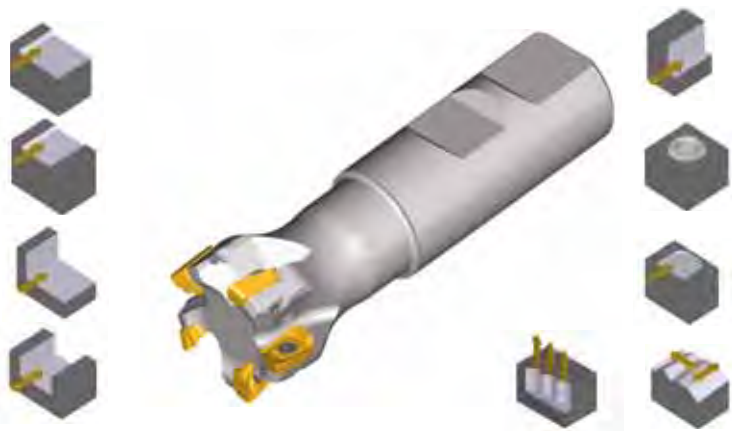
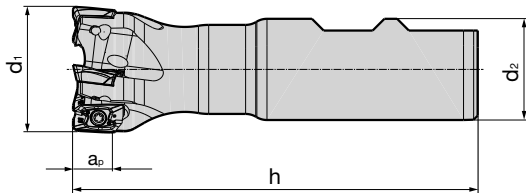

Abmessungen in mm		Dimensions in mm			z	Bestellbezeichnung Ordering code	Verfügbarkeit Availability	Ersatzteile Spare parts	
$d_1$	$d_2$	$h$	$a_{p/90}$	$a_{p/HFC}$				Spann- schraube Fixation screw AP02-25068 5085706	Torx- Schlüssel Torque wrench 8IP 5088519
16	16	85	9	1,5	2	BE90 LD10.016 Z02	●		
20	20	90	9	1,5	3	BE90 LD10.020 Z03	●		
25	25	106	9	1,5	3	BE90 LD10.025 Z03	●		
25	25	106	9	1,5	4	BE90 LD10.025 Z04	●		
32	32	124	9	1,5	3	BE90 LD10.032 Z03	●		
32	32	124	9	1,5	5	BE90 LD10.032 Z05	●		

● Verfügbar ab Lager Available from stock

Bestellbeispiel Order example:  
1 Stück Piece BF90 LD10.040 Z04

Schnittgeschwindigkeit siehe Seite 52  
Cutting data recommendations page 52

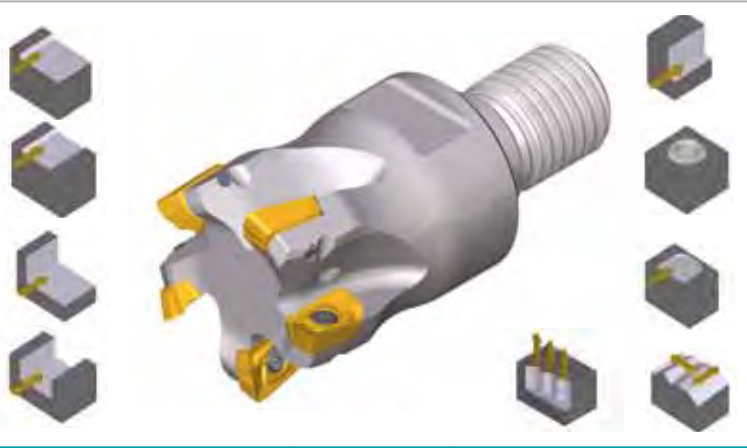
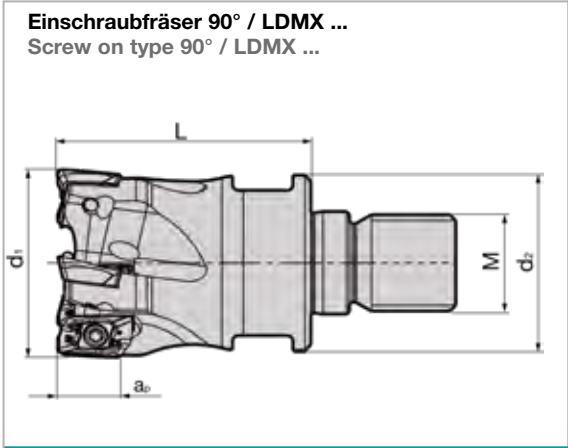

Abmessungen in mm / Dimensions in mm							Bestellbezeichnung / Ordering code	Verfügbarkeit / Availability	Ersatzteile / Spare parts	
d <sub>1</sub>	d <sub>2</sub>	L	a <sub>p/90</sub>	a <sub>p/HFC</sub>	M	z				
16	13,8	29	9	1,5	M8	2	<b>BS90 LD10.016 Z02 M08</b>	●	 Spannschraube / Fixation screw AP02-25068 5085706	 Torx-Schlüssel / Torque wrench 8IP 5088519
20	18	29	9	1,5	M10	3	<b>BS90 LD10.020 Z03 M10</b>	●		
25	21	32	9	1,5	M12	3	<b>BS90 LD10.025 Z03 M12</b>	●		
25	21	32	9	1,5	M12	4	<b>BS90 LD10.025 Z04 M12</b>	●		
32	29	42	9	1,5	M16	5	<b>BS90 LD10.032 Z05 M16</b>	●		

Bestellbeispiel / Order example: 1 Stück / Piece BS90 LD10.016 Z02 M08

N = Anzahl der Schneidkanten / N = Number of cutting edges	Bestellbezeichnung / Ordering code	l	d	s	d <sub>1</sub>	r	Schneidstoffsorten / Cutting materials											
							Ident No.											
							BCP20M	BCP25M	BCP30M	BCP35M	BCP40M	BCM35M	BCM40M	BCK15M	BCK20M	BCN10M	BWN10M	
 90° Platten/90° inserts	LDMX 100408 SR-MP	10	6,6	4,76	2,8	0,8	●			●								
	LDMX 100408 SR-MM	10	6,6	4,76	2,8	0,8							●					
	LDMX 100408 ER-MK	10	6,6	4,76	2,8	0,8									●			
 HFC Platten/HFC insert	LDMX 100415 SR-MPH	1,5	6,6	4,76	2,8	1,5	●			●								
	LDMX 100415 ER-MMH	1,5	6,6	4,76	2,8	1,5							●					

Bestellbeispiel / Order example: 10 Stück / Pieces LDMX 100408 SR-MP BCP35M

● Verfügbar ab Lager / Available from stock

Sortenbeschreibung Seite 8-9 / Description of grades page 8-9

Schnittgeschwindigkeit Seiten 52 / Cutting data recommendations pages 52

## Multifunktional Multi Functional

**Ø 40 - 125**  
**Aufsteckfräser**  
 Face Milling Cutter  
 Plattengröße 10 und 14  
 Insert size 10 and 14

**Ø 25 - 32**  
**Schaftfräser**  
 End Milling Cutter  
 Plattengröße 10  
 Insert size 10

**Ø 25 - 40**  
**Einschraubfräser**  
 Screw on type 90°  
 Plattengröße 10  
 Insert size 10

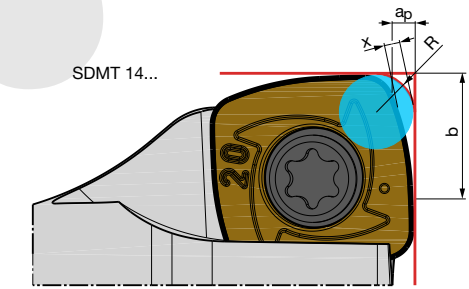
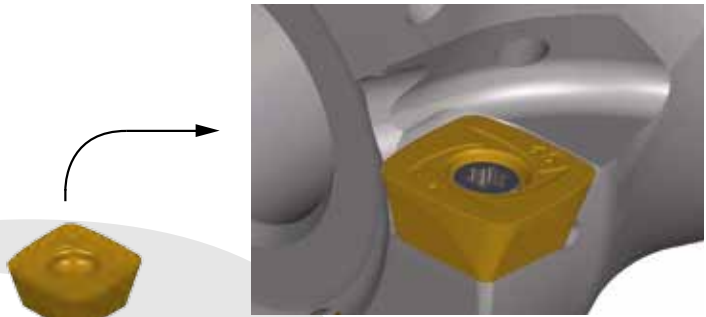

SDM..	R	ap	x	b
10	2,25	1,1	0,62	8,033
14	3,45	2,2	0,93	10,868

### Besondere Merkmale: Fräsen HFC

- Multifunktionales Werkzeugsystem für höchste Produktivität
- 1 Grundkörper für 2 Bearbeitungsverfahren = Multifunktional
- Erleichterung der Lagerhaltung und der Werkzeugbeschaffung durch weniger Artikel
- 4 real einsetzbare Schneiden
- Leichter Schnitt auch in Vollnuten durch perfekt abgestimmte Fräsgeometrie
- Optimale Aufnahme der axialen Schnittkräfte durch spezielle Anordnung von Radien an der Schneidkante
- Höchste Zahnvorschübe (bis  $f_z = 2,5$  mm bei SDMT 14)
- Einschraubfräser in Kombination mit den VHM-Verlängerungen minimieren Schwingungen bei Auskragungen bis 300 mm

### Special features: Milling HFC

- multifunctional tool system for highest productivity
- 1 basic body for 2 machining operations = multifunctional
- facilitation of storage and tool procurement through less articles
- 4 real usable cutting edges
- smooth cut also on full groove due to perfect coordinated milling geometry
- optimal consumption of the axial cutting forces due to special layout of the radii on the cutting edge
- highest tooth feed ( up to  $f_z = 2.5$  mm with SDMT 14)
- screw on type milling cutter in combination with solid carbide extensions minimize vibrations on overhangs up to 300 mm

Optimale Schnittwerte aus Tabelle ersichtlich!  
 Optimal cutting data see chart!

Schnittgeschwindigkeit Seite 52  
 Cutting speed page 52

WSP Geometrie Insert geometry	Schnitttiefe Cutting depth [ mm ] $a_p$ max SDM..10...	Vorschub Feed [ mm ] $f_z$ SDM..10...	Schnitttiefe Cutting depth [ mm ] $a_p$ max SDM..14...	Vorschub Feed [ mm ] $f_z$ SDM..14...
MPH	0,5 <b>0,8</b> 1,1	0,7 <b>1</b> 1,6	0,6 <b>1,5</b> 2,2	0,7 <b>1,4</b> 2,5
MMH	0,5 <b>0,8</b> 1,1	0,7 <b>1</b> 1,6	0,6 <b>1,5</b> 2,2	0,7 <b>1,4</b> 2,5
RPH	0,5 <b>1</b> 1,1	0,9 <b>1,1</b> 1,6	0,6 <b>1,5</b> 2,2	0,7 <b>1,6</b> 2,5
RKH	0,5 <b>1</b> 1,1	0,9 <b>1,1</b> 1,6	0,6 <b>1,5</b> 2,2	0,7 <b>1,6</b> 2,5

# DELTAtec 90P Feed

## Multifunktional Multi Functional

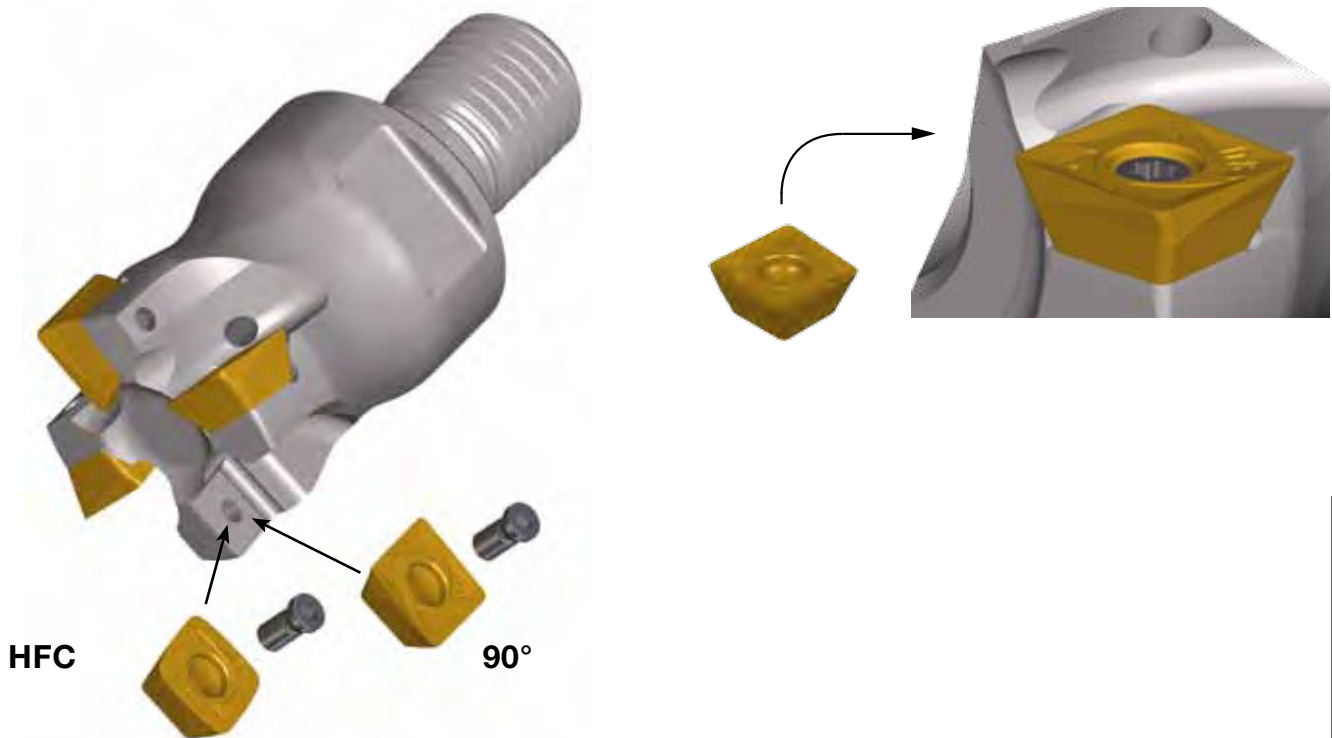

### Besondere Merkmale: Fräsen 90°

- Exakte 90° bei 4 Schneiden
- Leichter Schnitt durch positive Grundgeometrie
- Ungleichteilung führt zu Schwingungsreduktion und extremer Laufruhe
- Maximale Produktivitätssteigerung durch hohes Zerspanvolumen je Schneide
- Prozesssicherheit durch gutes Verschleißverhalten und Stabilisierung der Schneidkante aufgrund spezieller Plattengeometrien

### Special features: Milling 90°

- exactly 90° on 4 cutting edges
- smooth cut due to positive basic geometry
- unequal division leads to reduction of vibration and extremely smooth running
- maximum productivity increase due to high metal removal per cutting edge
- process security due to non problematic wear behaviour and stabilisation of the cutting edge through special insert geometry

WSP Geometrie Insert geometry	Schnitttiefe Cutting depth [ mm ] $a_p$ max SDM..10...	Vorschub Feed [ mm ] $f_z$ SDM..10...	Schnitttiefe Cutting depth [ mm ] $a_p$ max SDM..14...	Vorschub Feed [ mm ] $f_z$ SDM..14...
MP	0,8 <b>4,9</b> 9,0	0,08 <b>0,16</b> 0,25	1,2 <b>6,6</b> 12	0,1 <b>0,19</b> 0,28
MM	0,8 <b>4,9</b> 9,0	0,08 <b>0,11</b> 0,15	1,2 <b>6,6</b> 12	0,1 <b>0,14</b> 0,18
MK	0,8 <b>4,9</b> 9,0	0,08 <b>0,19</b> 0,3	1,2 <b>6,6</b> 12	0,1 <b>0,17</b> 0,23

Optimale Schnittwerte aus Tabelle ersichtlich!  
Optimal cutting data see chart!

Schnittgeschwindigkeit Seite 52  
Cutting speed page 52

**Aufsteckfräser 90° / SDM...**  
Face milling cutter 90° / SDMT...

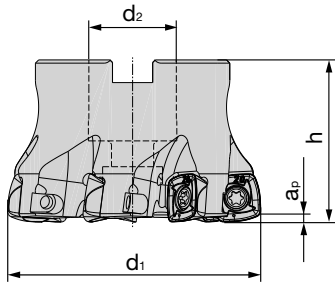

Abmessungen in mm		Dimensions in mm			z	Bestellbezeichnung Ordering code	Verfügbarkeit Availability	Ersatzteile Spare parts	
d <sub>1</sub>	d <sub>2</sub>	h	a <sub>p/90</sub>	a <sub>p/HFC</sub>				A13-30070 5085707	Torx-Schlüssel Torque wrench T9 5088515
40	16	40	7	1,5	4	BF90 SD10.040 Z04	●	A13-30070 5085707	Torx-Schlüssel Torque wrench T9 5088515
40	16	40	7	1,5	6	BF90 SD10.040 Z06	●		
50	22	40	7	1,5	5	BF90 SD10.050 Z05	●		
50	22	40	7	1,5	7	BF90 SD10.050 Z07	●		
63	22	40	7	1,5	6	BF90 SD10.063 Z06	●		
63	22	40	7	1,5	8	BF90 SD10.063 Z08	●		
80	27	50	7	1,5	8	BF90 SD10.080 Z08	●		
50	22	40	11,5	2,5	5	BF90 SD14.050 Z05	●		
63	22	40	11,5	2,5	6	BF90 SD14.063 Z06	●		
80	27	50	11,5	2,5	7	BF90 SD14.080 Z07	●		
100	32	50	11,5	2,5	9	BF90 SD14.100 Z09	●		
125	40	60	11,5	2,5	11	BF90 SD14.125 Z11	●		

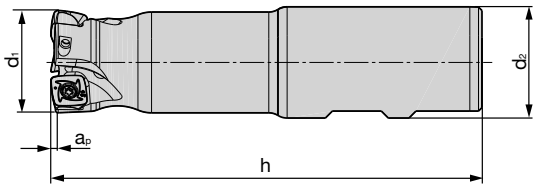

**Schaftfräser 90° / SDM...**  
End milling cutter 90° / SDMT...



Abmessungen in mm		Dimensions in mm			z	Bestellbezeichnung Ordering code	Verfügbarkeit Availability	Ersatzteile Spare parts	
d <sub>1</sub>	d <sub>2</sub>	h	a <sub>p/90</sub>	a <sub>p/HFC</sub>				A13-30070 5085707	Torx-Schlüssel Torque wrench T9 5088515
25	25	106	7	1,5	2	BE90 SD10.025 Z02	●	Spannschraube Fixation screw A13-30070 5085707	Torx-Schlüssel Torque wrench T9 5088515
32	32	124	7	1,5	3	BE90 SD10.032 Z03	●		



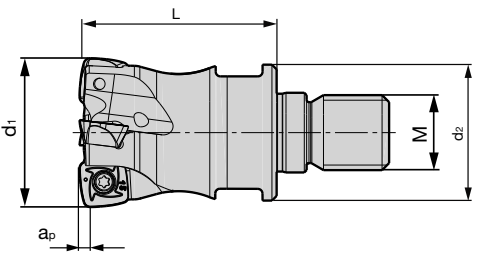

● Verfügbar ab Lager Available from stock  
 Bestellbeispiel Order example: 1 Stück Piece BF90 SD10.040 Z04  
 Schnittgeschwindigkeit siehe Seite 52 Cutting data recommendations page 52

**Einschraubfräser 90° / SDM....**  
Screw on type 90° / SDM. ...

Abmessungen in mm		Dimensions in mm				z	⚙	Bestellbezeichnung Ordering code	Verfügbarkeit Availability	Ersatzteile Spare parts	
d <sub>1</sub>	d <sub>2</sub>	L	a <sub>p/90</sub>	a <sub>p/HFC</sub>	M					Spann- schraube Fixation screw A13-30070 5085707	Torx- Schlüssel Torque wrench T9 5088515
25	24	32	7	1,5	M12	2	BS90 SD10.025 Z02 M12	●			
32	29	42	7	1,5	M16	4	BS90 SD10.032 Z04 M16	●			
40	29	42	7	1,5	M16	4	BS90 SD10.040 Z04 M16	●			

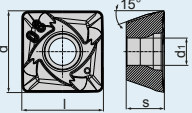
Bestellbeispiel Order example: 1 Stück Piece BS90 SD10.025 Z02 M12

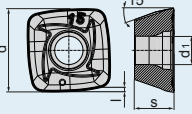
N = Anzahl der Schneidkanten N = Number of cutting edges	Bestellbezeichnung Ordering code	l	d	s	d <sub>1</sub>	r	Schneidstoffsorten Cutting materials Ident No.													
							BCP20M	BCP25M	BCP30M	BCP35M	BCP40M	BCM35M	BCM40M	BCK15M	BCK20M	BCN10M	BWN10M			
    N = 4	<b>90° Platten/90° inserts</b>																			
	SDMT 100408 SR-MP	10,4	10,4	4,86	3,5	0,8														
	SDMT 100408 ER-MM	10,4	10,4	4,86	3,5	0,8														
	SDMT 100408 SR-MK	10,4	10,4	4,86	3,5	0,8														
	SDMT 140512 SR-MP	14,8	14,8	5,2	5,5	1,2														
	SDMT 140512 ER-MM	14,8	14,8	5,2	5,5	1,2														
	SDMT 140512 SR-MK	14,8	14,8	5,2	5,5	1,2														
	<b>HFC Platten/HFC inserts</b>																			
	SDMT 100415 SR-MPH	1,1	10,2	4,76	3,5	1,5		●	●											
	SDMT 100415 ER-MMH	1,1	10,2	4,76	3,5	1,5														
	SDMT 140520 SR-MPH	2,2	14,7	5	5,5	2		●	●											
	SDMT 140520 ER-MMH	2,2	14,7	5	5,5	2														
	SDMW 100415 SR-RPH	1,1	10,2	4,76	3,5	1,5				●	●									
	SDMW 100415 SR-RKH	1,1	10,2	4,76	3,5	1,5														
SDMW 140520 SR-RPH	2,2	14,7	5	5,5	2				●	●										
SDMW 140520 SR-RKH	2,2	14,7	5	5,5	2															

Bestellbeispiel Order example: 10 Stück Pieces SDMX 100408 SR-MP BCP35M

Sortenbeschreibung Seite 8-9  
Description of grades page 8-9

● Verfügbar ab Lager Available from stock

Schnittgeschwindigkeit Seiten 52  
Cutting data recommendations pages 52

**Ø 50 - 250**  
**Aufsteckfräser**  
 Face Milling Cutter  
 Plattengröße 12  
 Insert size 12

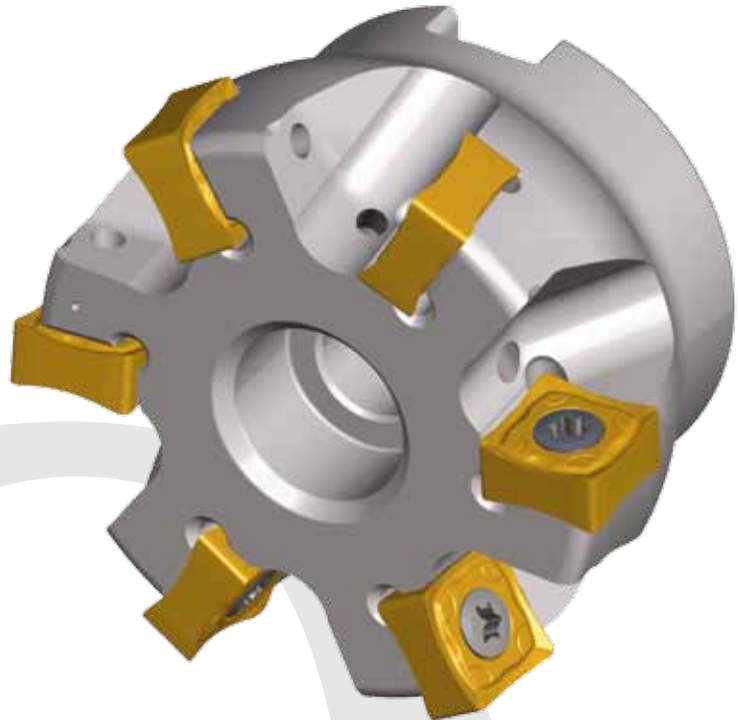

**Besondere Merkmale:**

- Stabiles Eckenfräsen (Schruppen)
- Anstellwinkel 88° mit 8 Schneiden
- 0,8 oder 1,2 Eckenradius verfügbar
- Enge und sehr enge Teilung der Werkzeuge
- Ab Durchmesser 160 ohne innere Kühlmittelzufuhr
- Artikel mit Status "Auf Anfrage" in fünf Arbeitstagen lieferbar

**Special features:**

- stable edge milling
- approach angle 88° with 8 cutting edges
- 0.8 or 1.2 corner radius available
- narrow and very narrow division of the tools
- from diameter 160 no internal coolant supply
- article with status "On request" are deliverable in five working days

WSP Geometrie Insert geometry	Schnitttiefe Cutting depth [ mm ] $a_p$ max	Vorschub Feed [ mm ] $f_z$
MP	1 5 10	0,1 <b>0,2</b> 0,25
MM	1 5 10	0,1 <b>0,18</b> 0,22
MK	1 5 10	0,1 <b>0,2</b> 0,25

Optimale Schnittwerte aus Tabelle ersichtlich!  
 Optimal cutting data see chart!

Schnittwertempfehlungen Seiten 52  
 Cutting data recommendations pages 52



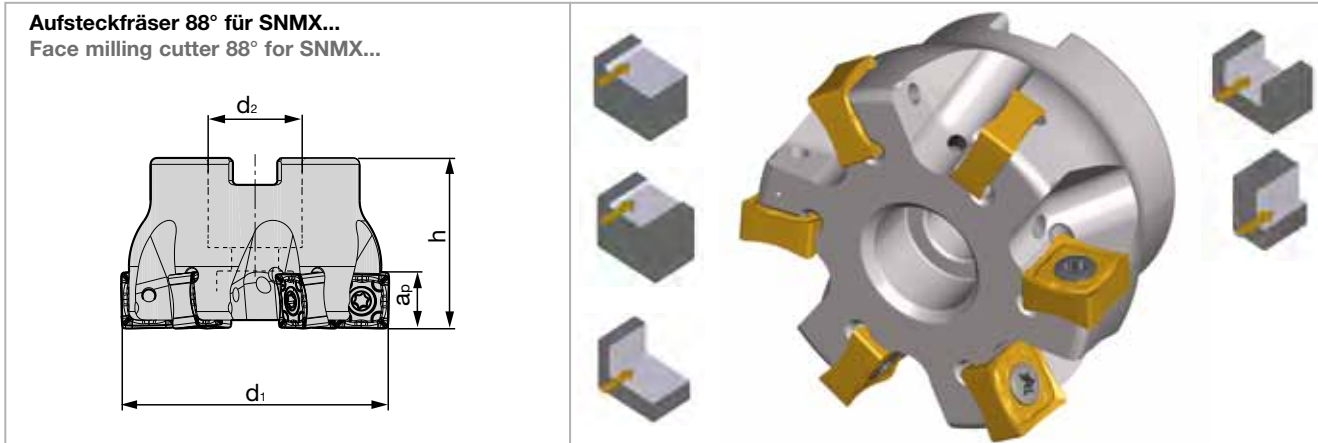

Abmessungen in mm / Dimensions in mm					Bestellbezeichnung / Ordering code	Verfügbarkeit / Availability	Ersatzteile / Spare parts	
d <sub>1</sub>	a <sub>p</sub>	h	d <sub>2</sub>	z				
50	11	40	22	4	<b>BF88 SN12.050 Z04</b>	●	 Spannschraube / Fixation screw A06-40115 5084080	 Torx-Schlüssel / Torque wrench T15 5088516
63	11	40	22	6	<b>BF88 SN12.063 Z06</b>	●		
80	11	50	27	7	<b>BF88 SN12.080 Z07</b>	●		
80	11	50	27	9	<b>BF88 SN12.080 Z09</b>	○		
100	11	50	32	8	<b>BF88 SN12.100 Z08</b>	●		
100	11	50	32	11	<b>BF88 SN12.100 Z11</b>	○		
125	11	63	40	10	<b>BF88 SN12.125 Z10</b>	●		
125	11	63	40	14	<b>BF88 SN12.125 Z14</b>	○		
160	11	63	40	12	<b>BF88 SN12.160 Z12 NC</b>	○		
160	11	63	40	18	<b>BF88 SN12.160 Z18 NC</b>	○		
200	11	63	60	14	<b>BF88 SN12.200 Z14 NC</b>	○		
200	11	63	60	22	<b>BF88 SN12.200 Z22 NC</b>	○		
250	11	63	60	16	<b>BF88 SN12.250 Z16 NC</b>	○		
250	11	63	60	24	<b>BF88 SN12.250 Z24 NC</b>	○		

Bestellbeispiel Order example: 1 Stück Piece BF88 SN12.050 Z04

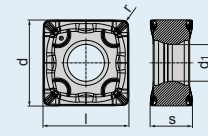
N = Anzahl der Schneidkanten N = Number of cutting edges	Bestellbezeichnung Ordering code	l	d	s	d <sub>1</sub>	r	Schneidstoffsorten Cutting materials Ident No.											
							BCP20M	BCP25M	BCP30M	BCP35M	BCP40M	BCM35M	BCM40M	BCK15M	BCK20M	BCN10M	BWN10M	
 N = 4	<b>SNMX 120608 SN-MP</b>	12,70	12,70	6,35	5,2	0,8			●	●								
	<b>SNMX 120608 SN-MM</b>	12,70	12,70	6,35	5,2	0,8					●							
	<b>SNMX 120608 SN-MK</b>	12,70	12,70	6,35	5,2	0,8							●	●				
	<b>SNMX 120612 SN-MP</b>	12,70	12,70	6,35	5,2	1,2			●	●								
	<b>SNMX 120612 SN-MK</b>	12,70	12,70	6,35	5,2	1,2								●	●			

Bestellbeispiel Order example: 10 Stück Pieces SNMX 120608 SN-MP BCP25M

- Verfügbar ab Lager Available from stock
- Verfügbar auf Anfrage Available on request

Sortenbeschreibung Seite 8-9  
Description of grades page 8-9

Schnittwertempfehlungen Seiten 52  
Cutting data recommendations pages 52

**Ø 40 - 125**  
**Aufsteckfräser**  
 Face Milling Cutter  
 Plattengröße 10 und 16  
 Insert size 10 and 16

**Ø 12 - 40**  
**Schaftfräser**  
 End Milling Cutter  
 Plattengröße 10 und 16  
 Insert size 10

**Ø 16 - 32**  
**Einschraubfräser**  
 Screw on type 90°  
 Plattengröße 10  
 Insert size 10 and 16

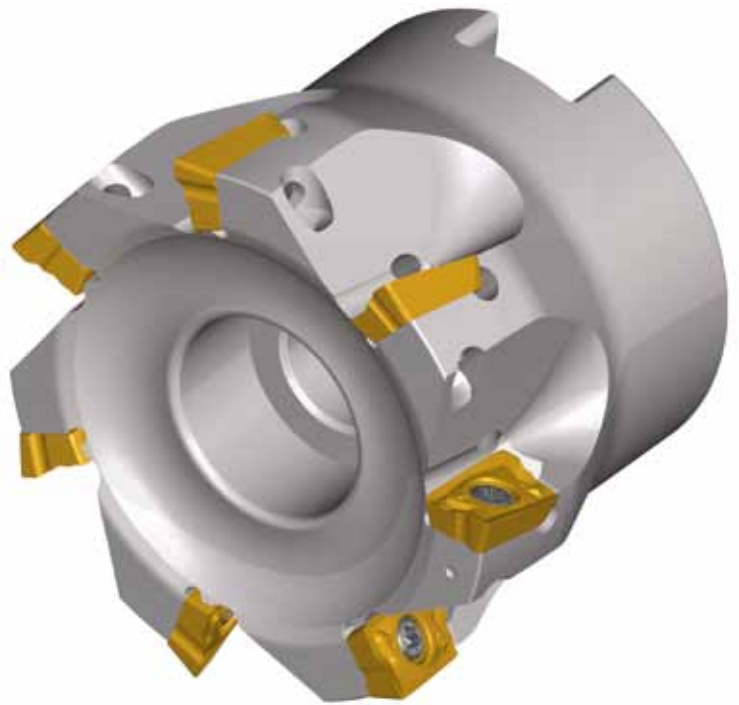

### Besondere Merkmale:

- Hybride Geometrie
- ISO Platte mit Helix Schneidkante und präzisiertem Schnitt
- Vielfältiges Geometrieangebot
- Vielfältiges Sortenangebot
- Beste Zerspanungsergebnisse nur in Kombination Boehlerit Wendeschneidplatte + Boehlerit Werkzeuge erreichbar
- BP und BM Geometrie nur als Schruppvariante einsetzbar
- Einschraubwerkzeuge in Kombination mit den schwingungsdämpfenden VHM-Verlängerungen
- Spezielle Geometrie für mittlere Bearbeitung MP2 und für Schruppbearbeitung RP2 von Stahl

### Special features:

- hybrid geometry
- ISO insert with helix cutting edge and accurate cutting
- varied geometry offer
- varied grade offer
- best cutting results only in combination with Boehlerit inserts + Boehlerit tools achievable
- BP and BM geometry only applicable in roughing version
- screw on type tools in combination with vibration damping solid carbide extensions
- special geometry for medium machining MP2 and for roughing RP2 of steel

Optimale Schnittwerte aus Tabelle ersichtlich!  
 Optimal cutting data see chart!

Schnittgeschwindigkeit Seite 52  
 Cutting speed page 52

WSP Geometrie Insert geometry	Schnitttiefe Cutting depth [ mm ]		Vorschub Feed [ mm ]	
	$a_p$ max APKT 10...	$f_z$ APKT 10...	$a_p$ max APKT 16...	$f_z$ APKT 16...
MP2	0,5 <b>3</b> 9	0,1 <b>0,15</b> 0,2	1 <b>8</b> 15	0,1 <b>0,15</b> 0,2
MM2	0,5 <b>3</b> 9	0,1 <b>0,15</b> 0,2	1 <b>8</b> 15	0,1 <b>0,15</b> 0,2
RP2	0,5 <b>3</b> 9	0,2 <b>0,22</b> 0,28	1 <b>8</b> 15	0,2 <b>0,25</b> 0,3
RK2	0,5 <b>3</b> 9	0,2 <b>0,25</b> 0,3	1 <b>8</b> 15	0,2 <b>0,27</b> 0,35
BP	0,5 <b>3</b> 9	0,2 <b>0,25</b> 0,3	1 <b>8</b> 15	0,2 <b>0,25</b> 0,3
BM	0,5 <b>3</b> 9	0,12 <b>0,18</b> 0,25	1 <b>8</b> 1	0,12 <b>0,18</b> 0,25

**Aufsteckfräser 90° / AP.T ...**  
Face milling cutter 90° / AP.T ...

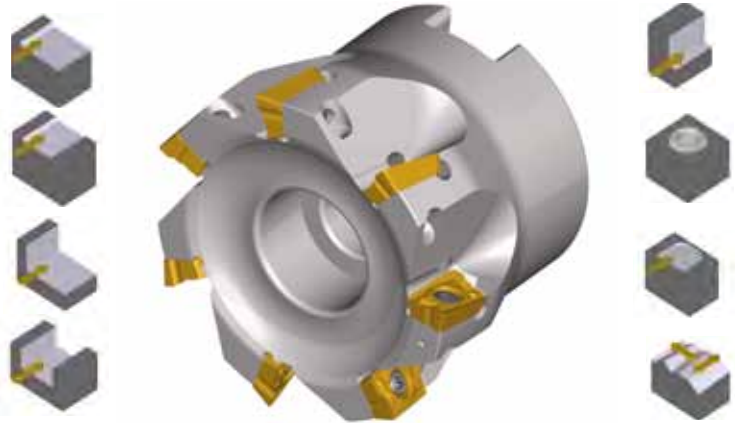
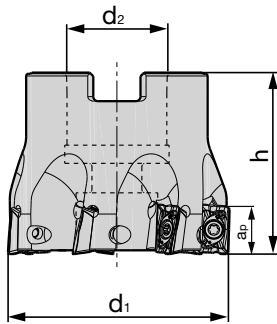

Abmessungen in mm		Dimensions in mm		z	Bestellbezeichnung Ordering code	Verfügbarkeit Availability	Ersatzteile Spare parts	
d <sub>1</sub>	d <sub>2</sub>	d <sub>3</sub>	a <sub>p</sub>				h	Spannschraube Fixation screw AP17-25055 5085710
40	16	-	9	40	6	●		
50	22	-	9	40	6	●		
50	22	-	9	40	7	●		
63	22	-	9	40	8	●		
80	27	-	9	50	10	●		

**Aufsteckfräser 90° / AP.T ...**  
Face milling cutter 90° / AP.T ...

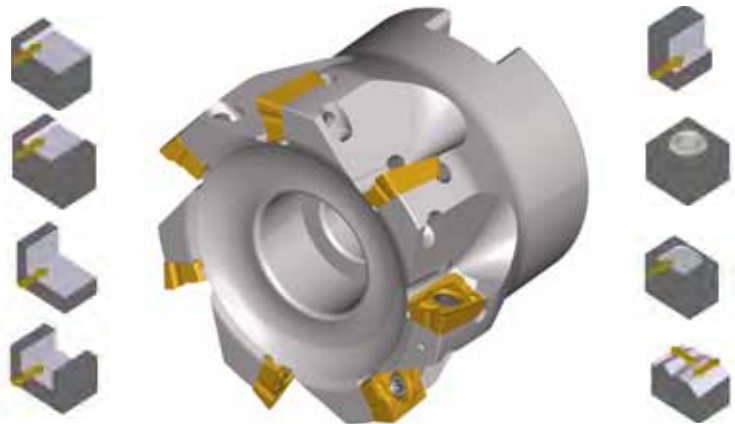
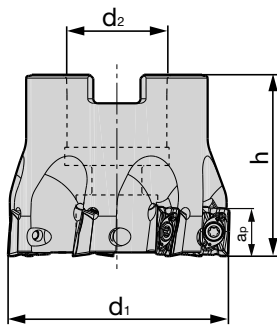

Abmessungen in mm		Dimensions in mm		z	Bestellbezeichnung Ordering code	Verfügbarkeit Availability	Ersatzteile Spare parts	
d <sub>1</sub>	d <sub>2</sub>	d <sub>3</sub>	a <sub>p</sub>				h	Spannschraube Fixation screw AP02-40095 5085711
40	16	-	9	40	4	●		
50	22	-	9	40	5	●		
63	22	-	15	40	6	●		
80	27	-	15	50	7	●		
100	32	-	15	50	8	●		
125	40	-	15	63	9	●		

● Verfügbar ab Lager Available from stock

Bestellbeispiel Order example:  
1 Stück Piece BF90 AP10.040 Z06

Schnittwertempfehlungen siehe Seite 52  
Cutting data recommendations page 52

**Schaftfräser 90° / AP.T...**  
End milling cutter 90° / AP.T...

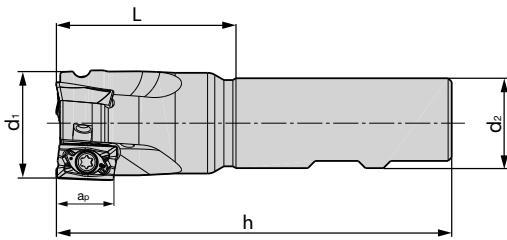

Abmessungen in mm		Dimensions in mm			Z	Bestellbezeichnung Ordering code	Verfügbarkeit Availability	Ersatzteile Spare parts	
d <sub>1</sub>	d <sub>2</sub>	h	a <sub>p</sub>	L				Spannschraube Fixation screw	Torx-Schlüssel Torque wrench
12	16	80	9	32	1	<b>BE90 AP10.012 Z01</b>	●	 AP17-25055 <b>5085710</b>	 8IP <b>5088519</b>
16	16	85	9	37	2	<b>BE90 AP10.016 Z02</b>	●		
20	20	90	9	40	3	<b>BE90 AP10.020 Z03</b>	●		
25	25	105	9	49	4	<b>BE90 AP10.025 Z04</b>	●		
32	25	110	9	54	5	<b>BE90 AP10.032 Z05</b>	●		

**Schaftfräser 90° / AP.T...**  
End milling cutter 90° / AP.T...

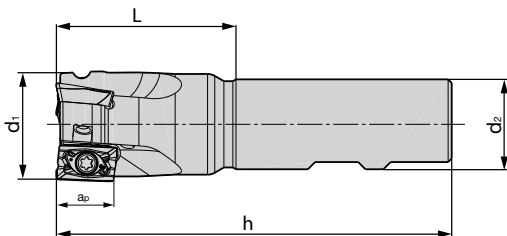

Abmessungen in mm		Dimensions in mm			Z	Bestellbezeichnung Ordering code	Verfügbarkeit Availability	Ersatzteile Spare parts	
d <sub>1</sub>	d <sub>2</sub>	h	a <sub>p</sub>	L				Spannschraube Fixation screw	Torx-Schlüssel Torque wrench
25	20	100	15	40	2	<b>BE90 AP16.025 Z02</b>	●	 AP02-40095 <b>5085711</b>	 15IP <b>5088520</b>
32	25	110	15	50	3	<b>BE90 AP16.032 Z03</b>	●		
40	32	115	15	55	4	<b>BE90 AP16.040 Z04</b>	●		

● Verfügbar ab Lager Available from stock

Bestellbeispiel Order example:  
1 Stück Piece BF90 AP10.012 Z01

Schnittwertempfehlungen siehe Seite 52  
Cutting data recommendations page 52

**Einschraubfräser 90° / A.P.T ...**  
Screw on type 90° / A.P.T ...

Abmessungen in mm		Dimensions in mm		z	Bestellbezeichnung Ordering code	Verfügbarkeit Availability	Ersatzteile Spare parts	
d <sub>1</sub>	d <sub>2</sub>	L	a <sub>p</sub>				M	
16	12,7	23	9	M8	2	●	 Spannschraube Fixation screw AP17-25055 5085710	 Torx-Schlüssel Torque wrench 8IP 5088519
20	17,7	30	9	M10	3	●		
25	20,7	35	9	M12	4	●		
32	28,7	43	9	M16	5	●		

Bestellbeispiel Order example: 1 Stück Piece BS90 AP10.016 Z02 M8

N = Anzahl der Schneidkanten N = Number of cutting edges	Bestellbezeichnung Ordering code	Schneidstoffsorten Cutting materials Ident No.															
		l	d	s	d <sub>1</sub>	r	BCP20M	BCP25M	BCP30M	BCP35M	BCP40M	BCM35M	BCM40M	BCK15M	BCK20M	BCN10M	BWN10M
  N = 4	APKT 100304 SR-MP2	10	6,7	3,5	2,8	0,4	●		●								
	APKT 100304 SR-MM2	10	6,7	3,5	2,8	0,4						●					
	APKT 100304 SR-RP2	10	6,7	3,5	2,8	0,4				●							
	APKT 100304 SR-RK2	10	6,7	3,5	2,8	0,4									●		
	APKT 160408 SR-MP2	16	9,52	5,26	4,5	0,8	●		●								
	APKT 160408 SR-MM2	16	9,52	5,26	4,5	0,8							●				
	APKT 160408 SR-RP2	16	9,52	5,26	4,5	0,8				●							
	APKT 160408 SR-RK2	16	9,52	5,26	4,5	0,8									●		
	APKT 1003 PDSR-BP	10	6,7	3,5	2,8	0,5	●	●	●					●	●		
	APKT 1003 PDSR-BM	10	6,7	3,5	2,8	0,5							●				
	APKT 1604 PDSR-BP	16	9,52	5,26	4,5	0,8	●	●	●					●			
	APKT 1604 PDSR-BM	16	9,52	5,26	4,5	0,8							●				
	APKT 160416 SR-BP	16	9,52	5,26	4,5	1,6			●								
	APKT 160424 SR-BP	16	9,52	5,26	4,5	2,4			●								
APKT 160432 SR-BP	16	9,52	5,26	4,5	3,2			●									

Bestellbeispiel Order example: 10 Stück Pieces APHT 100304 SR-MP2 BCP25M

Sortenbeschreibung Seite 8-9  
Description of grades page 8-9

● Verfügbar ab Lager Available from stock

Schnittwertempfehlungen siehe Seite 52  
Cutting data recommendations page 52

**Ø 40 - 80**  
**Aufsteckfräser**  
Face Milling Cutter  
Plattengröße 10 und 15  
Insert size 10 and 15

**Ø 20 - 40**  
**Schaftfräser**  
End Milling Cutter  
Plattengröße 10  
Insert size 10

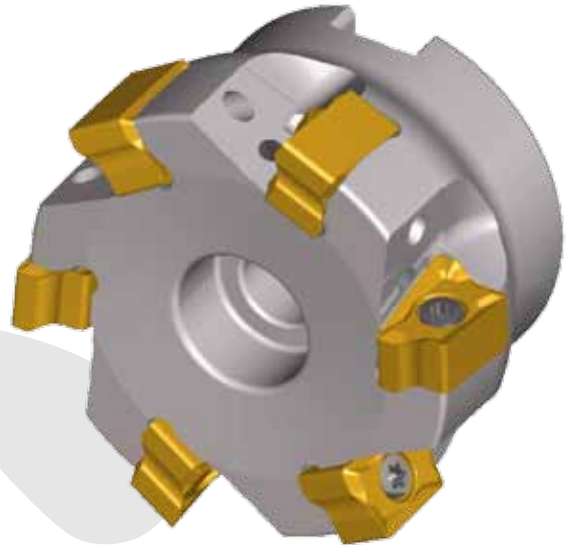

## Besondere Merkmale: Fräsen 90°

- Stabiles Werkzeugsystem durch negatives Geometriegrundkonzept
- Effektiv positiver Spanwinkel für leichten Schnitt
- Produktivität ist gewährleistet durch 4 Schneidkanten
- Verfügbar in 2 Plattengrößen
- Schaftfräser in XL Länge verfügbar
- Artikel mit Status "Auf Anfrage" in fünf Arbeitstagen lieferbar





## Special features: Milling 90°

- stable tool system through negative geometry basic design
- effective positive chip angle for smooth cut
- productivity guaranteed through 4 cutting edges
- available in 2 insert sizes
- end milling cutter in XL length available
- article with status "On request" are deliverable in five working days

WSP Geometrie Insert geometry	Schnitttiefe Cutting depth [ mm ] $a_p$ max LNMX 10...		Vorschub Feed [ mm ] $f_z$ LNMX 10...	
	1	3,5 6	0,15	0,25 0,35
RP	1	5 13	0,15	0,25 0,35
RK	1	3,5 6	0,15	0,2 0,30

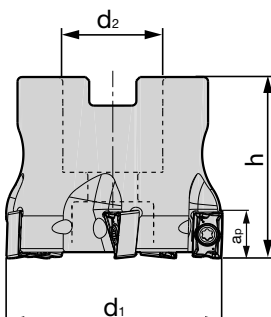
Optimale Schnittwerte aus Tabelle ersichtlich!  
Optimal cutting data see chart!

Schnittwertempfehlungen siehe Seite 52  
Cutting data recommendations page 52

Aufsteckfräser 90° / LNMX ... Face milling cutter 90° / LNMX ...									
Abmessungen in mm		Dimensions in mm		$z$ 	Bestellbezeichnung Ordering code	Verfügbarkeit Availability	Ersatzteile Spare parts		
$d_1$	$d_2$	$d_3$	$a_p$				$h$	 Spannschraube Fixation screw A02-30076 5084082	 Torx-Schlüssel Torque wrench T9 5088515
40	16	-	9	40	4	●			
40	16	-	9	40	5	●			
50	22	-	9	40	5	●			
50	22	-	9	40	7	●			

● Verfügbar ab Lager Available from stock

Bestellbeispiel Order example:  
1 Stück Piece BF90 LN10.040 Z04

Schnittwertempfehlungen siehe Seite 52  
Cutting data recommendations page 52

### Aufsteckfräser 90° / LNMX ... Face milling cutter 90° / LNMX ...

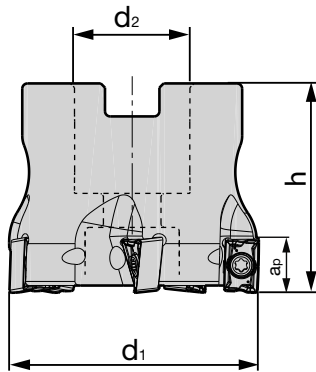

Abmessungen in mm		Dimensions in mm		z	Bestellbezeichnung Ordering code	Verfügbarkeit Availability	Ersatzteile Spare parts	
d <sub>1</sub>	d <sub>2</sub>	d <sub>3</sub>	a <sub>p</sub>				h	
50	22	-	14	40	3	●	 Spannschraube Fixation screw AP13-40110 5084084	 Torx-Schlüssel Torque wrench 15IP 5088520
50	22	-	14	40	4	●		
63	22	-	14	40	4	●		
63	22	-	14	40	6	●		
80	27	-	14	50	5	●		
80	27	-	14	50	7	●		

### Schaftfräser 90° / LNMX ... End milling cutter 90° / LNMX ...

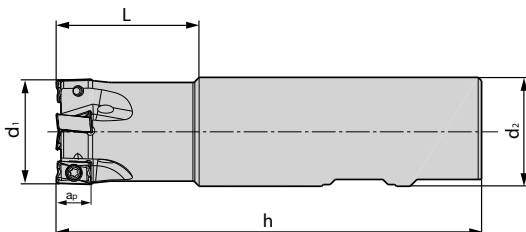



Abmessungen in mm		Dimensions in mm		z	Bestellbezeichnung Ordering code	Verfügbarkeit Availability	Ersatzteile Spare parts		
d <sub>1</sub>	d <sub>2</sub>	h	a <sub>p</sub>				L		
20	20	100	9	30	2	●	 Spannschraube Fixation screw A02-30076 5084082	 Torx-Schlüssel Torque wrench T9 5088515	
20	19	150	9	30	2	○			
20	20	100	9	30	3	○			
25	25	115	9	35	2	●			
25	24	150	9	35	2	○			
25	25	115	9	35	3	●			
32	32	125	9	42	3	●			
32	30	180	9	42	3	○			
32	32	125	9	42	4	●			
40	32	130	9	42	4	●			
40	32	130	9	42	5	●			

- Verfügbar ab Lager Available from stock
- Verfügbar auf Anfrage Available on request



Bestellbeispiel Order example:  
1 Stück Piece BF90 LN15.050 Z03

Schnittwertempfehlungen siehe Seite 52  
Cutting data recommendations page 52

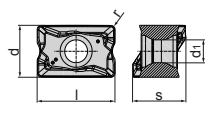

Abmessungen in mm / Dimensions in mm						Bestellbezeichnung / Ordering code	Verfügbarkeit / Availability	Ersatzteile / Spare parts	
d <sub>1</sub>	d <sub>2</sub>	h	a <sub>p</sub>	L	z				
32	32	125	14	40	3	<b>BE90 LN15.032 Z03</b>	●	 Spannschraube / Fixation screw AP13-40110 5084084	 Torx-Schlüssel / Torque wrench 15IP 5088520
40	32	125	14	40	3	<b>BE90 LN15.040 Z03</b>	●		
40	32	125	14	40	4	<b>BE90 LN15.040 Z04</b>	●		

Bestellbeispiel Order example: 1 Stück Piece BE90 LN15.032 Z03

N = Anzahl der Schneidkanten / N = Number of cutting edges	Bestellbezeichnung / Ordering code	l	d	s	d <sub>1</sub>	r	Schneidstoffsorten / Cutting materials												
							Ident No.												
							BCP20M	BCP25M	BCP30M	BCP35M	BCP40M	BCM35M	BCM40M	BCK15M	BCK20M	BCN10M	BWN10M		
  N = 4	LNMX 100605 SR-RP	10	6,6	6,35	2,8	0,5		●											
	LNMX 100605 SR-RK	10	6,6	6,35	2,8	0,5													
	LNMX 151008SR-RP	15	9,52	10,0	4,5	0,5		●											
	LNMX 151008SR-RK	15	9,52	10,0	4,5	0,5													

Bestellbeispiel Order example: 10 Stück Pieces LNMX 100605 SR-RP BCP25M

Sortenbeschreibung Seite 8-9 / Description of grades page 8-9

● Verfügbar ab Lager Available from stock

Schnittwertempfehlungen Seite 52 / Cutting data recommendations page 52

**Ø 50 - 80**  
**Aufsteckfräser**  
 Face Milling Cutter  
**Plattengröße 13**  
 Insert size 13

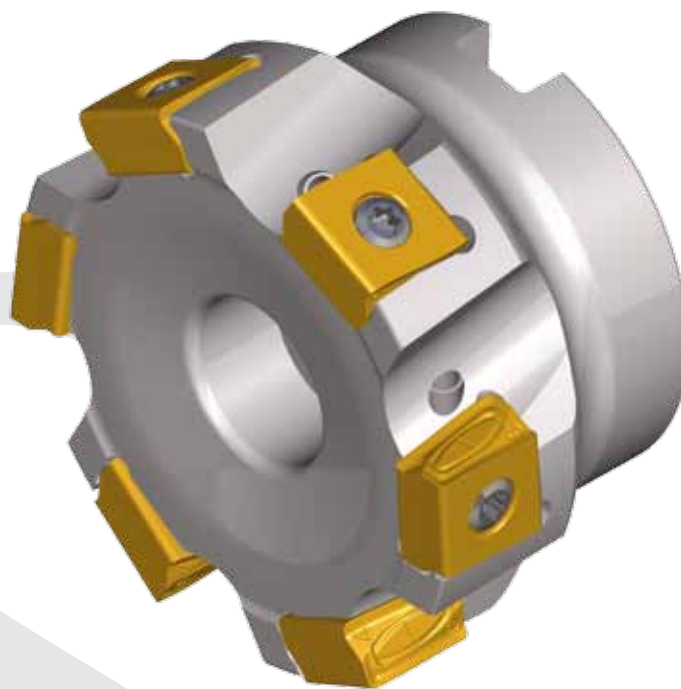

### Besondere Merkmale: Fräsen 90°

- Durch tangentielle Klemmung der Platten ergibt sich ein sehr stabiles Werkzeugsystem
- Produktivität gewährleistet durch 4 Schneiden
- Hohe Bearbeitungssicherheit durch dicke Tangentialplatte
- Leichter Schnitt durch Helixgeometrie an den Schneidkanten

### Special features: Milling 90°

- due to tangential clamping of the inserts a very stable tool system result
- productivity guaranteed through 4 cutting edges
- high machining security through thick tangential milling insert
- smooth cut through helix geometry on the cutting edges

WSP Geometrie Insert geometry	Schnitttiefe Cutting depth [ mm ] a <sub>p</sub> max	Vorschub Feed [ mm ] f <sub>z</sub>
RP	1 <b>6,5</b> 12	0,2 <b>0,3</b> 0,4
RK	1 <b>6,5</b> 12	0,25 <b>0,35</b> 0,45

Optimale Schnittwerte aus Tabelle ersichtlich!  
Optimal cutting data see chart!

Schnittwertempfehlungen Seite 52  
Cutting data recommendations page 52

**Aufsteckfräser 45° für LNMX..**  
Face milling cutter 45° for LNMX...

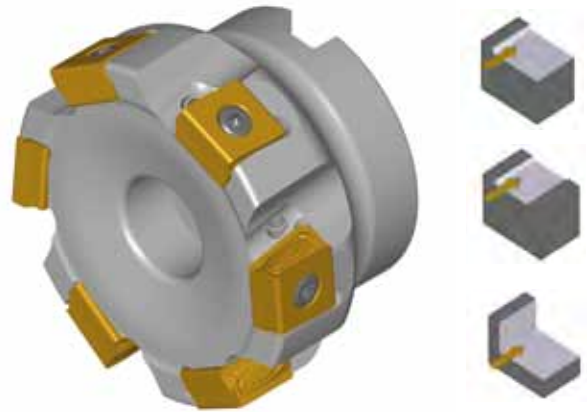
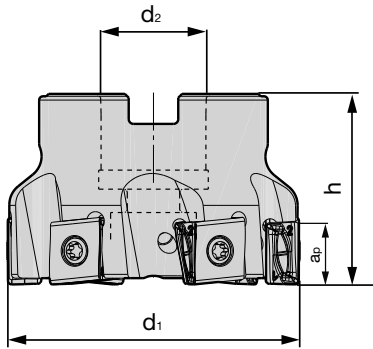

Abmessungen in mm Dimensions in mm				z	Bestellbezeichnung Ordering code	Verfügbarkeit Availability	Ersatzteile Spare parts	
$d_1$	$d_2$	h	$a_p$					
50	22	40	12	4	<b>BF90 LN13.050 Z04</b>	●	Spannschraube Fixation screw AP02-40054 <b>5085714</b>	Torx-Schlüssel Torque wrench 15IP <b>5088520</b>
63	22	40	12	4	<b>BF90 LN13.063 Z04</b>	●		
63	22	40	12	6	<b>BF90 LN13.063 Z06</b>	●		
80	27	50	12	7	<b>BF90 LN13.080 Z07</b>	●		

Bestellbeispiel Order example: 1 Stück Piece BF90 LN13.050 Z04



N = Anzahl der Schneidkanten N = Number of cutting edges	Bestellbezeichnung Ordering code	l	d	s	$d_1$	r	Schneidstoffsorten Cutting materials Ident No.												
							BCP20M	BCP25M	BCP30M	BCP35M	BCP40M	BCM35M	BCM40M	BCK15M	BCK20M	BCN10M	BWN10M		
							 N = 4	<b>LNMX 131308 SR-RP</b>	13	7,94	13	4,6	0,8					●	●
	<b>LNMX 131308 SR-RK</b>	13	7,94	13	4,6	0,8									●				

Bestellbeispiel Order example: 10 Stück Piece LNMX 131308 SR-RK BCK20M

● Verfügbar ab Lager Available from stock

Sortenbeschreibung Seite 8-9  
Description of grades page 8-9

Schnittwertempfehlungen Seite 52  
Cutting data recommendations page 52

Werkstoff-Gruppe Material group	WSP -Sorte Insert grade				BCP20M	BCP25M	BCP30M		
	ISO Code		Trockenbe- arbeitung Dry machining	Nassbe- arbeitung Wet machining	P20	P25	P30		
	Werkstoff Material								
<b>P</b>	Baustahl Structural steel		●		190 - 290	175 - 265	160 - 240		
	Vergütungsstahl Heat treated steel		●		160 - 230	145 - 215	140 - 190		
	Werkzeugstahl Tool steel		●		145 - 210	130 - 190	120 - 175		
	Gehärteter Stahl Hardened steel		●		110 - 170		100 - 160		
	<b>M</b>	Nichtrostender Stahl Stainless steel	austenitisch austenitic		●		90 - 150		
			austenitisch gehärtet austenitic hardened		●		60 - 110		
<b>K</b>	Grauguss Grey cast iron		●	○		140 - 300			
	Gusseisen mit Kugelgraphit Nodular graphite cast iron		●	○		100 - 160			
<b>N</b>	Aluminium Aluminium		●	○					
	Kupfer und Kupferlegierungen Copper and copper alloys		●	○					
<b>S</b>	Warmfeste Legierungen Heat resistant alloys		○	●					
	Titanlegierungen Titanium alloys		○	●					

- empfohlene Anwendung recommended application
- alternative Anwendung um 30 - 50 % reduzieren  
alternative application by 30 - 50 % reduced

	BCP35M P35	BCP40M P40	BCM35M M35	BCM40M M40	BCK15M K15	BCK20M K20	BWN10M N10	BCN10M N10
	120 - 240	100 - 220				200 - 300		
	145 - 215	145 - 215				180 - 250		
	130 - 190	130 - 190				160 - 220		
						120 - 180		
	80 - 140	70 - 130	110 - 180	100 - 160				
			80 - 130	70 - 120				
					180 - 360	150 - 320		
					140 - 250	110 - 180		
							400 - 2500	500 - 3000
							120 - 400	160 - 500
				30 - 70			25 - 80	
				30 - 80			30 - 80	



**BOEHLERIT**

# **BULLtec Serie**

Schwerzerspanungsfräser

Member of the LEITZ Group

# **BULLtec Series**

Heavy duty face milling cutter





## **BULLtec**Serie **BULLtec**Serie

Das modulare BULLtec - Werkzeugsystem setzt Maßstäbe in Leistungsfähigkeit und Flexibilität. Es kann durch einfaches Austauschen von Kassetten und Wendeschneidplatten zum Plan- oder Eckfräsen unterschiedlichster Werkstoffe eingesetzt werden. Ein BULLtec - Werkzeugsystem besteht immer aus einem Grundkörper mit austauschbaren Kassetten für die Wendeschneidplatten.



Beim Wechseln der Kassetten sorgt eine Haltenut für eine stabile und präzise Verbindung zum Grundkörper – ohne Justierarbeiten. So lassen sich BULLtec - Werkzeuge schnell und einfach an spezielle Aufgaben anpassen oder bei Bedarf neu einrichten. Alle Kassetten für die Stahlbearbeitung haben dieselben Einbauteile und eine innovative Klemmhalterung für die Wendeschneidplatten. Sie ist zugänglich von zwei Seiten und macht das Auswechseln von Wendeschneidplatten in der Maschine verblüffend einfach. Dank speziell designter Anstellwinkel der Wendeschneidplatten zeichnen sich die BULLtec - Werkzeugsysteme durch einen sehr weichen Schnitt aus. Das schont Werkzeug sowie Maschine und führt zu deutlichen Standzeitverlängerungen.

The modular BULLtec tool system sets the standard in terms of performance and flexibility. Simply exchange of cartridges and indexable inserts for face or step milling to make it suitable for the widest range of materials. A BULLtec tool system consists always of a base body with exchangeable cartridges for the indexable inserts. When the cartridge is exchanged, a retention groove ensures stable and precise connection to the base body – without the need for any alignment. This is how BULLtec tools are easily and quickly adjusted for special tasks or re-equipped as needed. All cartridges for steel machining have the same installation components and an innovative clamp bracket for the indexable inserts that can be accessed from two sides, which makes the exchange of indexable inserts in the machine amazingly simple. Thanks to specifically designed angles of incidence for the indexable inserts, the BULLtec tool systems stand out with their extraordinarily gentle cut, protecting both tools and machine and leading to a significantly extended services life.



**Technologievorteile**  
 Technological advantages

**Kundennutzen**  
 Customer benefits

<p><b>BULLtec-System</b>                  Modulares Werkzeugsystem.                  Rasches und effizientes Umrüsten je nach Einsatzfall.                  Kürzeste Stillstandzeiten nach Werkzeugbeschädigung.                  Kassettentausch ohne Justierarbeiten.</p> <p><b>BULLtec-System</b>                  Modular tool system.                  Quick and efficient change according to the application. Shortest downtimes after tool damage. Change of cartridge without setting work.</p>		<p>Kürzeste Rüstzeiten bei Systemwechsel</p> <p>Shortest setup time after application</p>
<p>Schneller und einfacher Wendeschneidplattenwechsel durch das patentierte Spannsystem. Zwei Handgriffe genügen.</p> <p>Quick and simple change of insert due to the patented clamping system. Two hand movements are enough.</p>		<p>Leichtes Wechseln der Kassetten. Kürzeste Wechselzeit der Wendeschneidplatten</p> <p>Simple change of the cartridges. Shortest change time of the inserts</p>
<p>Auf die Anwendung und den Werkstoff optimierte Wendeschneidplattentypen und Geometrien (die beste Wendeschneidplatte für jeden Einsatzfall).</p> <p>Optimized insert types and geometries according to the application and to the material (the best insert for each application).</p>		<p>Hohe Wirtschaftlichkeit durch hohe Schnittgeschwindigkeiten und Trockenbearbeitung</p> <p>Big efficiency through big cutting speed and dry machining</p>

**Hinweis:** Kundenspezifische Ausführung auf Anfrage! Wir beraten Sie gerne!  
**Note:** Customized designs on request! We will be happy to advise you!

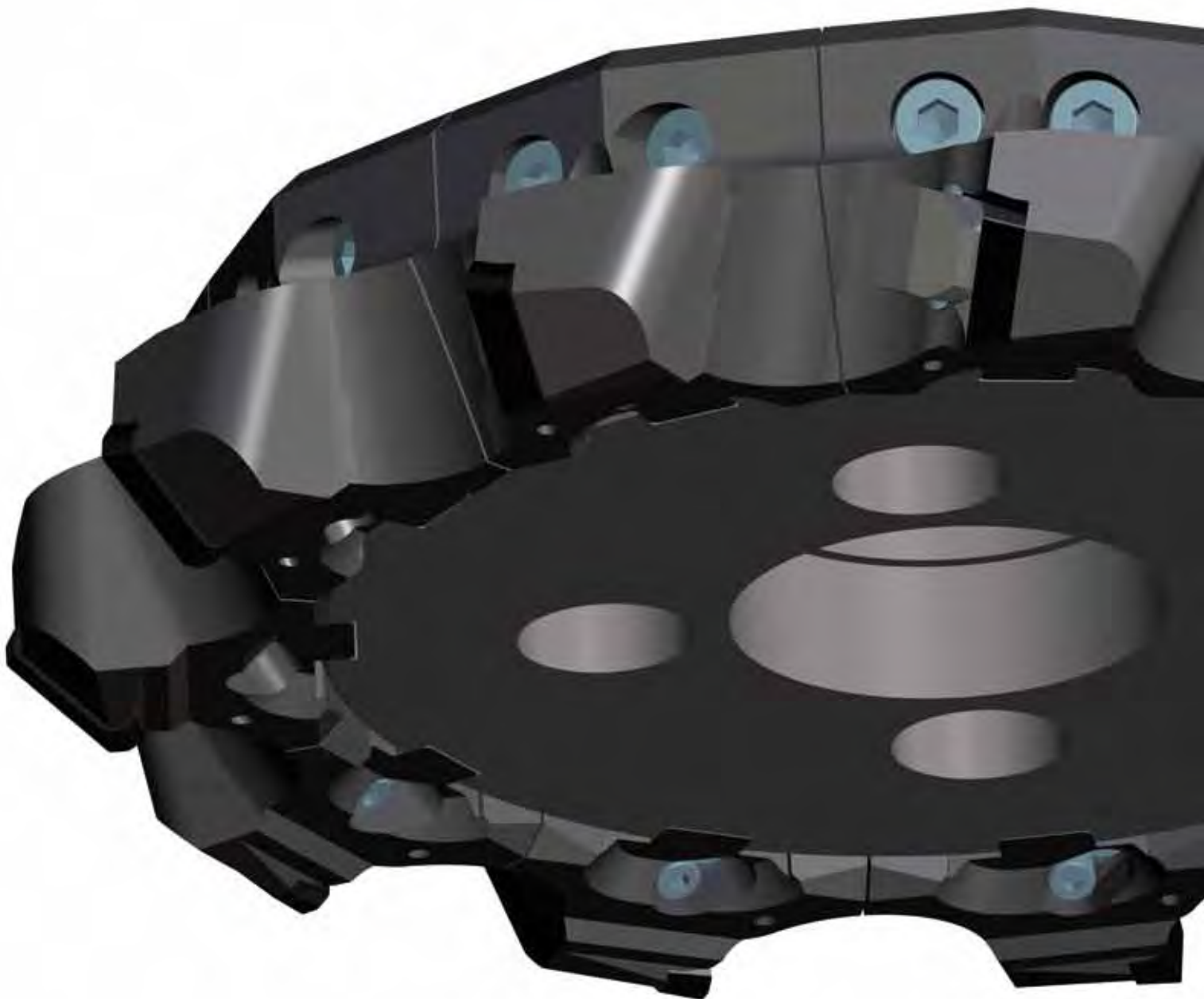

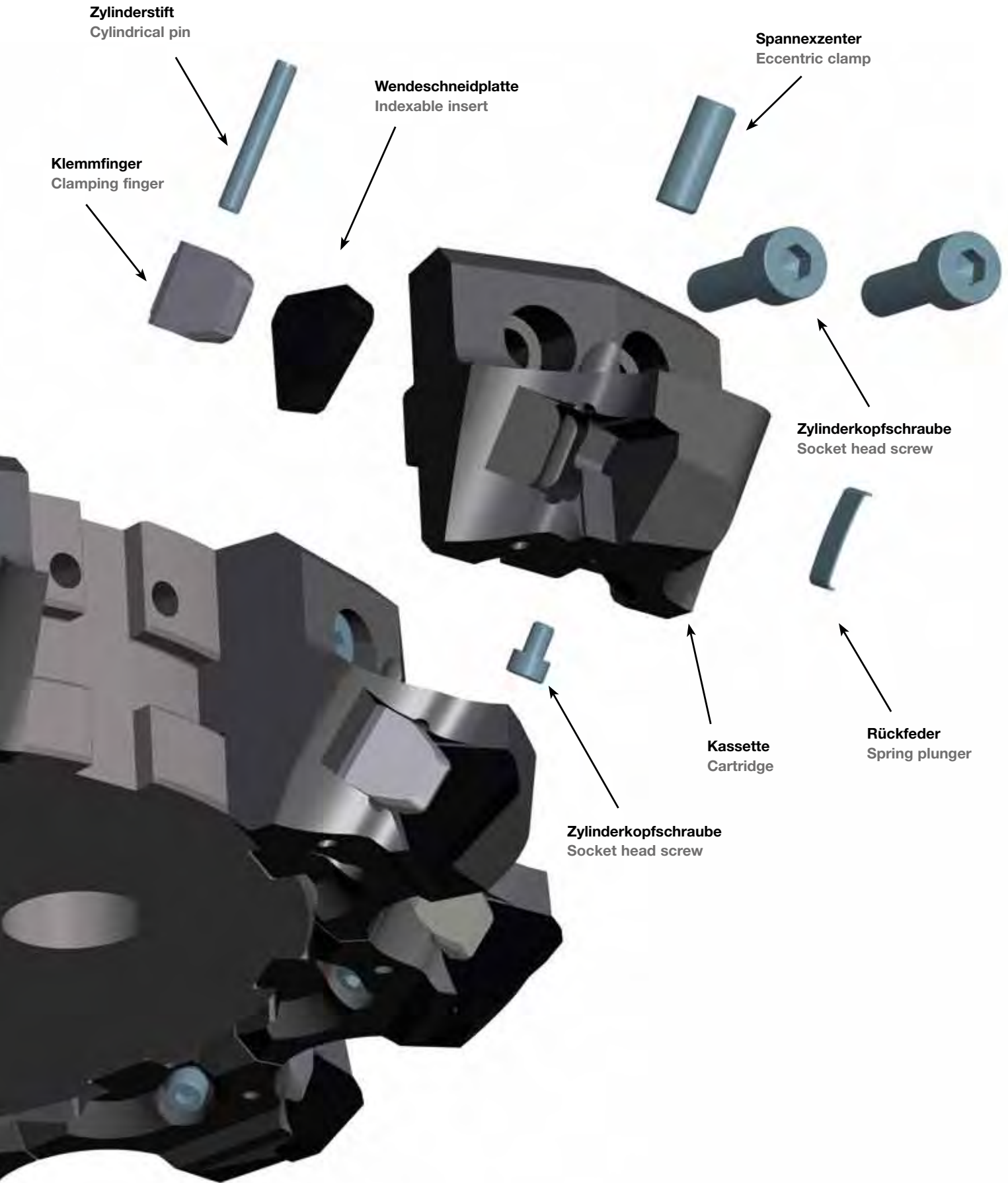



Sorte Grade	ISO	Anwendungsbereich Range of applications	Werkstoffgruppe Group of materials						Bearbeitungsverfahren Application					
			P	M	K	N	S	H	T	M	D	S	G	P
		01 05 10 15 20 25 30 35 40 45 50	Stahl Steel	Rostfrei Stainless	Grauguss Grey cast iron	NE-Metalle Non-ferrous metals	Hochwärmest High temperature materials	Harte Werkstoffe Hard materials	Drehen Turning	Fräsen Milling	Bohren Drilling	Gewinde- bearbeitung Threading	Einstechen Grooving	Abstechen Parting
<b>BCP30M</b>	HC-P30		■							●				
<b>BCM40M</b>	HC-M40			■						●				
<b>BWN20M</b>	HW-N20					■								
Anwendungsschwerpunkt Application peak			■ Hauptanwendung Main application □ Weitere Anwendung Further application						● Standardsorte Standard grade					
Gesamtbereich nach ISO 513 Full range to ISO 513		01 05 10 15 20 25 30 35 40 45 50												





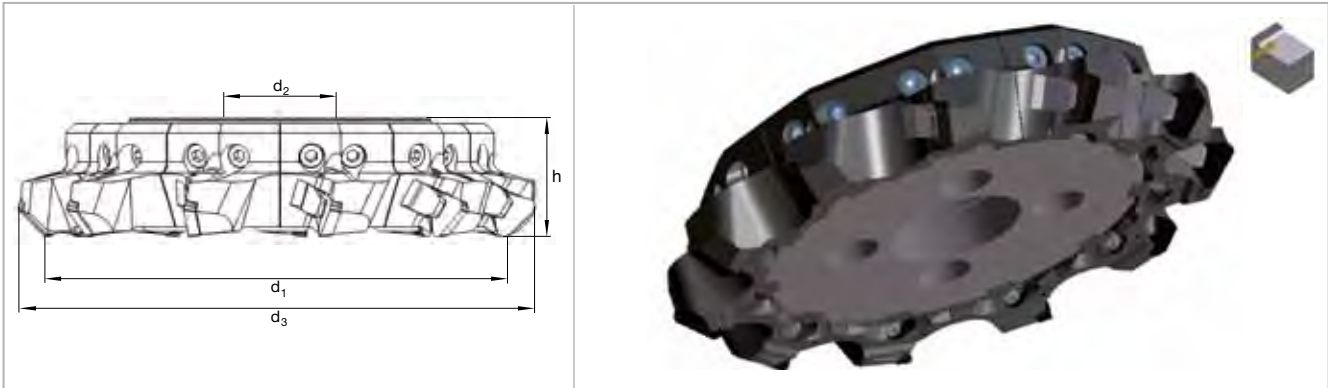

**Schneidstoffsorten  
Cutting Grades**



- BCP30M (HC-P30) TERAspeed 2.0  
Universelle Stahlfrässorte vor allem zum Planfräsen. Hohe Bearbeitungssicherheit auf einem breiten Stahlwerkstoffspektrum wird durch das besonders zähe Hartmetallsubstrat garantiert. Eine moderne HR-CVD Beschichtung bietet wirtschaftliche Trockenbearbeitung bei hohen Schnittgeschwindigkeiten.
- BCM40M (HC-M40)  
Extrem zähes, relativ feinkörniges Hartmetallsubstrat mit dünner, glatter PVD Beschichtung. Ideale Sorte zum Fräsen von austenitisch rostfreien Stählen und Werkstoffen aus der Duplexgruppe mit niedrigen bis mittleren Schnittgeschwindigkeiten. Auch für die Nassbearbeitung, jedoch wird Minimalmengenschmierung empfohlen.
- BWN20M (HW-N20)  
Universelle Sorte für die Bearbeitung von Aluminiumwerkstoffen und weiteren NE-Metallen.

- BCP30M (HC-P30) TERAspeed 2.0  
Universal steel milling grade especially for plain milling. The very tough carbide substrate guarantees high machining security on a wide range of steel materials. A modern HR-CVD coating ensures economic dry machining on high cutting speeds.
- BCM40M (HC-M40)  
Extremely tough, relative fine grained carbide substrate with thin, smooth PVD coating. Ideal grade for milling of austenitic stainless steels and materials from the Duplex group with low to medium cutting speeds. Also for wet machining, although minimum coolant supply is recommended.
- BWN20M (HW-N20)  
Universal grade for machining of aluminium materials and non-ferrous metals.

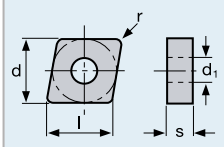

Abmessungen in mm Dimensions in mm					Bestellbezeichnung Ordering code	Verfügbarkeit Availability	Ersatzteile Spare parts	
d <sub>1</sub>	d <sub>3</sub>	h	d <sub>2</sub>	z				
200	228,5	63	60	9	<b>BF45 TP31.200C Z09 L</b>	○	 Zyl. Schraube Cylinder screw M8 x 25 <b>6412663</b>	 Inbus Schlüssel Socket head wrench V01A0060 <b>6407830</b>
200	228,5	63	60	9	<b>BF45 TP31.200C Z09 R</b>	○		
250	278,5	63	60	11	<b>BF45 TP31.250C Z11 L</b>	●		
250	278,5	63	60	11	<b>BF45 TP31.250C Z11 R</b>	●		
250	278,5	63	60	14	<b>BF45 TP31.250C Z14 L</b>	●		
250	278,5	63	60	14	<b>BF45 TP31.250C Z14 R</b>	●		
315	343,5	80	60	14	<b>BF45 TP31.315C Z14 L</b>	○		
315	343,5	80	60	14	<b>BF45 TP31.315C Z14 R</b>	●		
315	343,5	80	60	18	<b>BF45 TP31.315C Z18 L</b>	○		
315	343,5	80	60	18	<b>BF45 TP31.315C Z18 R</b>	●		
400	428,5	80	60	18	<b>BF45 TP31.400C Z18 L</b>	○		
400	428,5	80	60	18	<b>BF45 TP31.400C Z18 R</b>	○		
500	528,5	80	60	22	<b>BF45 TP31.500C Z22 L</b>	○		
500	528,5	80	60	22	<b>BF45 TP31.500C Z22 R</b>	○		

Kassette Cartridge	Bestellbezeichnung Ordering code	Verfügbarkeit Availability	Ersatzteile Spare parts				
							
  Anstellwinkel 45° Approach angle 45°	<b>C45 TP31.200 Z09 L</b>	○	Klemm-finger Clamping-finger <b>5086107</b>	Spann-exzenter Clamping eccentric <b>5085759</b>	Zylinder-schraube Cylinder screw M4 x 6 <b>5032151</b>	Rück feder Spring plunger SP01 <b>5085736</b>	Zylinder-stift Cylindrical pin CP01 <b>5060285</b>
	<b>C45 TP31.200 Z09 R</b>	○					
	<b>C45 TP31.250 Z11 L</b>	●					
	<b>C45 TP31.250 Z11 R</b>	●					
	<b>C45 TP31.250 Z14 L</b>	●					
	<b>C45 TP31.250 Z14 R</b>	●					
	<b>C45 TP31.315 Z14 L</b>	○					
	<b>C45 TP31.315 Z14 R</b>	●					
	<b>C45 TP31.315 Z18 L</b>	○					
	<b>C45 TP31.315 Z18 R</b>	●					
	<b>C45 TP31.400 Z18 L</b>	○					
	<b>C45 TP31.400 Z18 R</b>	○					
<b>C45 TP31.500 Z22 L</b>	○						
<b>C45 TP31.500 Z22 R</b>	○						
				Drehmoment Schlüssel Torque wrench <b>5076959</b>			

 Bestellbezeichnung Ordering code						Sorte Grade			
	l	d	s	r	d <sub>1</sub>	BGP30M	BCM40M	BWN20M	
<b>TPLN..</b>	<b>TPLN 3106 ADSN</b>	19,31	18,00	6,35	-	-	●	●	
									

● Verfügbar ab Lager Available from stock  
○ Verfügbar auf Anfrage Available on request

Bestellbeispiel Order example:  
1 Stück Piece BF45 TP31.200C Z09 L

Schnittwertempfehlungen siehe Seite 67  
Cutting data recommendations page 67

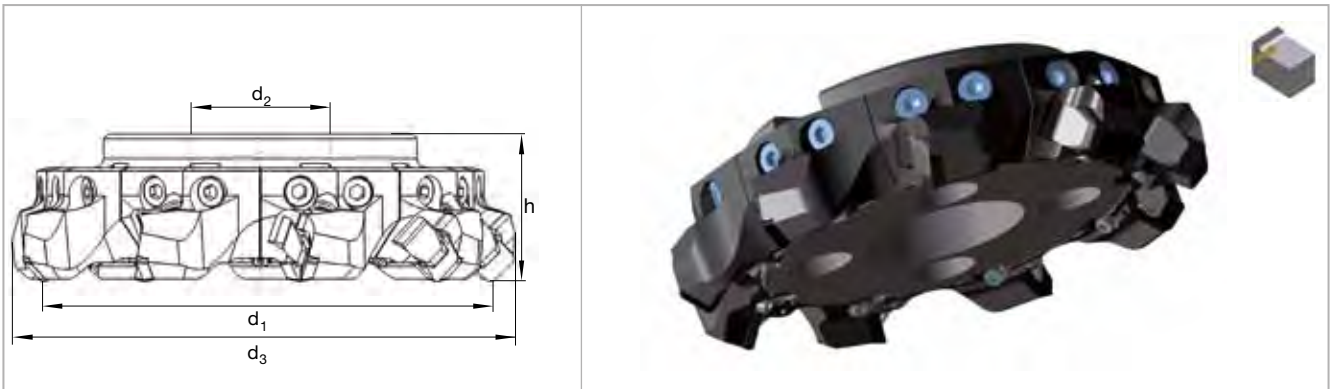

Abmessungen in mm Dimensions in mm					Bestellbezeichnung Ordering code	Verfügbarkeit Availability	Ersatzteile Spare parts	
d <sub>1</sub>	d <sub>3</sub>	h	d <sub>2</sub>	z				
200	220	63	60	11	<b>BF45 SE15.200C Z11 L</b>	○	 Zyl. Schraube Cylinder screw M8 x 25 <b>6412663</b>	 Inbus Schlüssel Socket head wrench V01A0060 <b>6407830</b>
200	220	63	60	11	<b>BF45 SE15.200C Z11 R</b>	○		
250	271,5	63	60	11	<b>BF45 SE15.250C Z11 L</b>	○		
250	271,5	63	60	11	<b>BF45 SE15.250C Z11 R</b>	●		
250	271,5	63	60	14	<b>BF45 SE15.250C Z14 L</b>	●		
250	271,5	63	60	14	<b>BF45 SE15.250C Z14 R</b>	●		
315	335	80	60	14	<b>BF45 SE15.315C Z14 L</b>	○		
315	335	80	60	14	<b>BF45 SE15.315C Z14 R</b>	●		
315	335	80	60	18	<b>BF45 SE15.315C Z18 L</b>	○		
315	335	80	60	18	<b>BF45 SE15.315C Z18 R</b>	●		
400	420	80	60	22	<b>BF45 SE15.400C Z22 L</b>	○		
400	420	80	60	22	<b>BF45 SE15.400C Z22 R</b>	○		
500	520	80	60	28	<b>BF45 SE15.500C Z28 L</b>	○		
500	520	80	60	28	<b>BF45 SE15.500C Z28 R</b>	○		

Kassette Cartridge	Bestellbezeichnung Ordering code	Verfügbarkeit Availability	Ersatzteile Spare parts				
  Anstellwinkel 45° Approach angle 45°	<b>C45 SE15.200 Z11 L</b>	○	Klemm-finger Feed-finger <b>5086107</b>	Spann-exzenter Clamping eccentric <b>5085759</b>	Zylinder-schraube Cylinder screw M4 x 6 <b>5032151</b>	Rück-feder Spring plunger SP01 <b>5085736</b>	Zylinder-stift Cylindrical pin CP01 <b>5060285</b>
	<b>C45 SE15.200 Z11 R</b>	○					
	<b>C45 SE15.250 Z11 L</b>	○					
	<b>C45 SE15.250 Z11 R</b>	●					
	<b>C45 SE15.250 Z14 L</b>	●					
	<b>C45 SE15.250 Z14 R</b>	●					
	<b>C45 SE15.315 Z14 L</b>	○					
	<b>C45 SE15.315 Z14 R</b>	●					
	<b>C45 SE15.315 Z18 L</b>	○					
	<b>C45 SE15.315 Z18 R</b>	●					
	<b>C45 SE15.400 Z22 L</b>	○					
	<b>C45 SE15.400 Z22 R</b>	○					
<b>C45 SE15.500 Z28 L</b>	○						
<b>C45 SE15.500 Z28 R</b>	○						
				Drehmoment Schlüssel Torque wrench <b>5076959</b>			

	Bestellbezeichnung Ordering code						Sorte Grade		
		l	d	s	r	d <sub>1</sub>	BCP30M	BCM40M	BWN20M
	<b>SEKN 1504 AFSN-MP</b>	15,88	15,88	4,76	-	-	●		
	<b>SEKN 1504 AFEN-MM</b>	15,55	15,88	4,76	-	-		●	





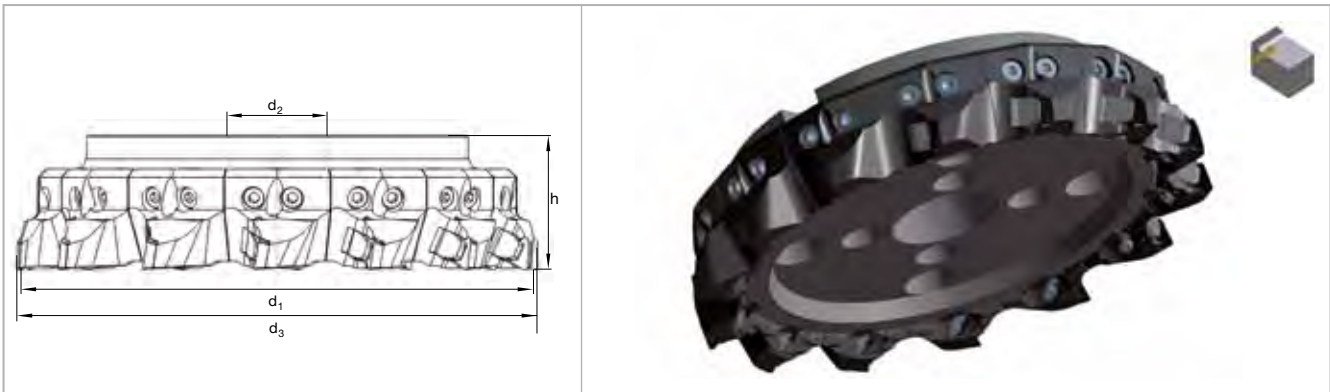

● Verfügbar ab Lager Available from stock  
○ Verfügbar auf Anfrage Available on request



Bestellbeispiel Order example:  
1 Stück Piece BF45 SE15.200C Z11 L

Schnittwertempfehlungen siehe Seite 67  
Cutting data recommendations page 67

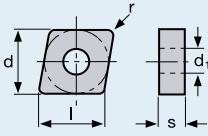

Abmessungen in mm Dimensions in mm					Bestellbezeichnung Ordering code	Verfügbarkeit Availability	Ersatzteile Spare parts	
d <sub>1</sub>	d <sub>3</sub>	h	d <sub>2</sub>	z				
250	250	63	60	11	<b>BF90 TP22.250C Z11 L</b>	○	 Zyl. Schraube Cylinder screw M8 x 25 <b>6412663</b>	 Inbus Schlüssel Socket head wrench V01A0060 <b>6407830</b>
250	250	63	60	11	<b>BF90 TP22.250C Z11 R</b>	●		
315	315	80	60	14	<b>BF90 TP22.315C Z14 L</b>	●		
315	315	80	60	14	<b>BF90 TP22.315C Z14 R</b>	●		
400	400	80	60	18	<b>BF90 TP22.400C Z18 L</b>	○		
400	400	80	60	18	<b>BF90 TP22.400C Z18 R</b>	○		
500	500	80	60	22	<b>BF90 TP22.500C Z22 L</b>	○		
500	500	80	60	22	<b>BF90 TP22.500C Z22 R</b>	○		

Kassette Cartridge	Bestellbezeichnung Ordering code	Verfügbarkeit Availability	Ersatzteile Spare parts				
							
  Anstellwinkel 90° Approach angle 90°	<b>C90 TP22.250 Z11 L</b>	○	Klemm- finger Clamping- finger <b>5086107</b>	Spann- exzenter Clamping eccentric <b>5085759</b>	Zylinder- schraube Cylinder screw M4 x 6 <b>5032151</b>	Rück- feder SP01 Spring plunger SP01 <b>5085736</b>	Zylinder- stift Cylindrical pin CP01 <b>5060285</b>
	<b>C90 TP22.250 Z11 R</b>	●					
	<b>C90 TP22.315 Z14 L</b>	●					
	<b>C90 TP22.315 Z14 R</b>	●					
	<b>C90 TP22.400 Z18 L</b>	○					
	<b>C90 TP22.400 Z18 R</b>	○					
	<b>C90 TP22.500 Z22 L</b>	○					
<b>C90 TP22.500 Z22 R</b>	○						
				 Drehmoment Schlüssel Torque wrench <b>5076959</b>			

 TPKN...	Bestellbezeichnung Ordering code						Sorte Grade		
		l	d	s	r	d <sub>1</sub>	BGP30M	BCM40M	BWN20M
	<b>TPLN 2206 PDS-R</b>	19,31	18,22	6,35	-	-	●		
	<b>TPLN 2206 PDS-L</b>	19,31	18,22	6,35	-	-	○		

● Verfügbar ab Lager Available from stock  
○ Verfügbar auf Anfrage Available on request

Bestellbeispiel Order example:  
1 Stück Piece BF90 TP22.250C Z11 L

Schnittwertempfehlungen siehe Seite 67  
Cutting data recommendations page 67

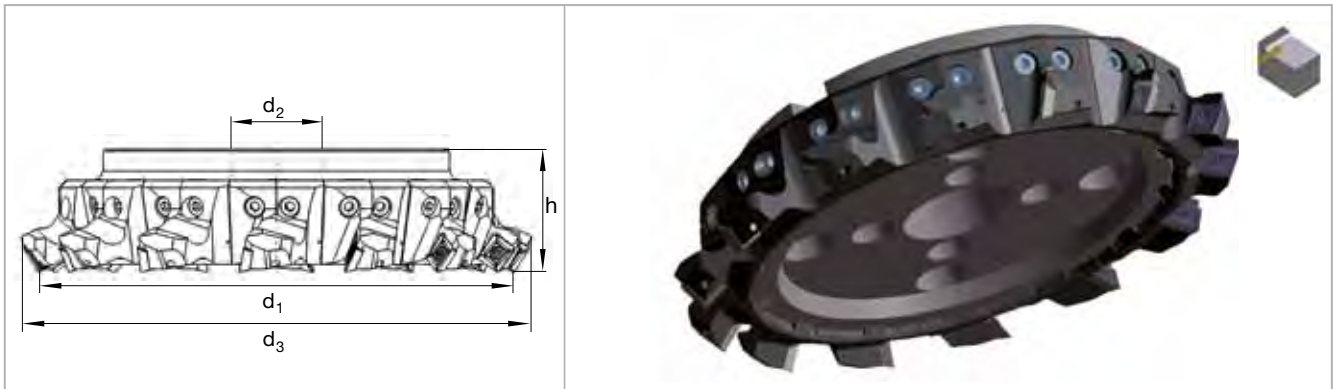

Abmessungen in mm		Dimensions in mm		z	Bestellbezeichnung Ordering code	Verfügbarkeit Availability	Ersatzteile Spare parts	
d <sub>1</sub>	d <sub>3</sub>	h	d <sub>2</sub>					
200	223	63	60	9	BF60 SF20.200C Z09 L	○	 Zyl. Schraube Cylinder screw M8 x 25 6412663	 Inbus Schlüssel Socket head wrench V01A0060 6407830
200	223	63	60	9	BF60 SF20.200C Z09 R	○		
250	273	63	60	11	BF60 SF20.250C Z11 L	○		
250	273	63	60	11	BF60 SF20.250C Z11 R	○		
315	338	80	60	14	BF60 SF20.315C Z14 L	○		
315	338	80	60	14	BF60 SF20.315C Z14 R	●		
400	423	80	60	18	BF60 SF20.400C Z18 L	○		
400	423	80	60	18	BF60 SF20.400C Z18 R	○		
500	523	80	60	22	BF60 SF20.500C Z22 L	○		
500	523	80	60	22	BF60 SF20.500C Z22 R	○		

Kassette Cartridge	Bestellbezeichnung Ordering code	Verfügbarkeit Availability	Ersatzteile Spare parts	
 Anstellwinkel 60° Approach angle 60°	C60 SF20.200 Z09 L	○	 Spannschraube Fixation screw A02-60160 6401270	 Torx-Schlüssel Torque wrench V04T2500 9078081
	C60 SF20.200 Z09 R	○		
	C60 SF20.250 Z11 L	○		
	C60 SF20.250 Z11 R	○		
	C60 SF20.315 Z14 L	○		
	C60 SF20.315 Z14 R	●		
	C60 SF20.400 Z18 L	○		
	C60 SF20.400 Z18 R	○		
	C60 SF20.500 Z22 L	○		
	C60 SF20.500 Z22 R	○		





Breitschicht Kassette Finishing Cartridge	Bestellbezeichnung Ordering code	Verfügbarkeit Availability	Ersatzteile Spare parts	
 Anstellwinkel 60° Approach angle 60°	C60 XF20.200 Z09 L	○	 Spannschraube Fixation screw A02-60160 6401270	 Torx-Schlüssel Torque wrench V04T2500 9078081
	C60 XF20.200 Z09 R	○		
	C60 XF20.250 Z11 L	○		
	C60 XF20.250 Z11 R	○		
	C60 XF20.315 Z14 L	○		
	C60 XF20.315 Z14 R	●		
	C60 XF20.400 Z18 L	○		
	C60 XF20.400 Z18 R	○		
	C60 XF20.500 Z22 L	○		
	C60 XF20.500 Z22 R	○		

● Verfügbar ab Lager Available from stock  
○ Verfügbar auf Anfrage Available on request

Bestellbeispiel Order example:  
1 Stück Piece BF60 SF20.200C Z09 L

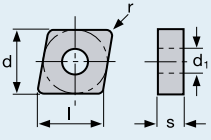
Schnittwertempfehlungen siehe Seite 67  
Cutting data recommendations page 67

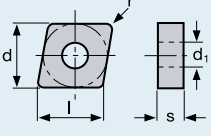

	<b>Bestellbezeichnung</b> Ordering code						Sorte Grade		
		l	d	s	r	d <sub>1</sub>	BCP30M	BCM40M	BWN20M
<b>XFHT..</b>   Breitschichtplatte Finishing insert	<b>XFHT 2006 DF-L</b>	20,00	20,00	6,00	-	6,50			○
	<b>XFHT 2006 DF-R</b>	20,00	20,00	6,00	-	6,50			●
	<b>Bestellbezeichnung</b> Ordering code						Sorte Grade		
		l	d	s	r	d <sub>1</sub>	BCP30M	BCM40M	BWN20M
	<b>SFHT..</b>  	<b>SFHT 2006 DG-L</b>	20,00	20,00	6,00	-	6,5		
<b>SFHT 2006 DG-R</b>		20,00	20,00	6,00	-	6,5			●

**Grundkörper**  
Basic Body

Abmessungen in mm Dimensions in mm				<b>Bestellbezeichnung</b> Ordering code	Verfügbarkeit Availability
d <sub>1</sub>	d <sub>2</sub>	h	z		
144	60	53	9	<b>BF200C09 L</b>	○
144	60	53	9	<b>BF200C09 R</b>	○
144	60	53	11	<b>BF200C11 L</b>	○
144	60	53	11	<b>BF200C11 R</b>	○
194	60	53	11	<b>BF250C11 L</b>	○
194	60	53	11	<b>BF250C11 R</b>	●
194	60	53	14	<b>BF250C14 L</b>	○
194	60	53	14	<b>BF250C14 R</b>	●
259	60	70	14	<b>BF315C14 L</b>	○
259	60	70	14	<b>BF315C14 R</b>	●
259	60	70	18	<b>BF315C18 L</b>	○
259	60	70	18	<b>BF315C18 R</b>	●
344	60	70	18	<b>BF400C18 L</b>	○
344	60	70	18	<b>BF400C18 R</b>	○
344	60	70	22	<b>BF400C22 L</b>	○
344	60	70	22	<b>BF400C22 R</b>	○
444	60	70	22	<b>BF500C22 L</b>	○
444	60	70	22	<b>BF500C22 R</b>	○
444	60	70	28	<b>BF500C28 L</b>	○
444	60	70	28	<b>BF500C28 R</b>	○

● Verfügbar ab Lager Available from stock  
○ Verfügbar auf Anfrage Available on request

Bestellbeispiel Order example:  
10 Stück Pieces XFHT 2006 DF-L BWN20M

Schnittwertempfehlungen siehe Seite 67  
Cutting data recommendations page 67

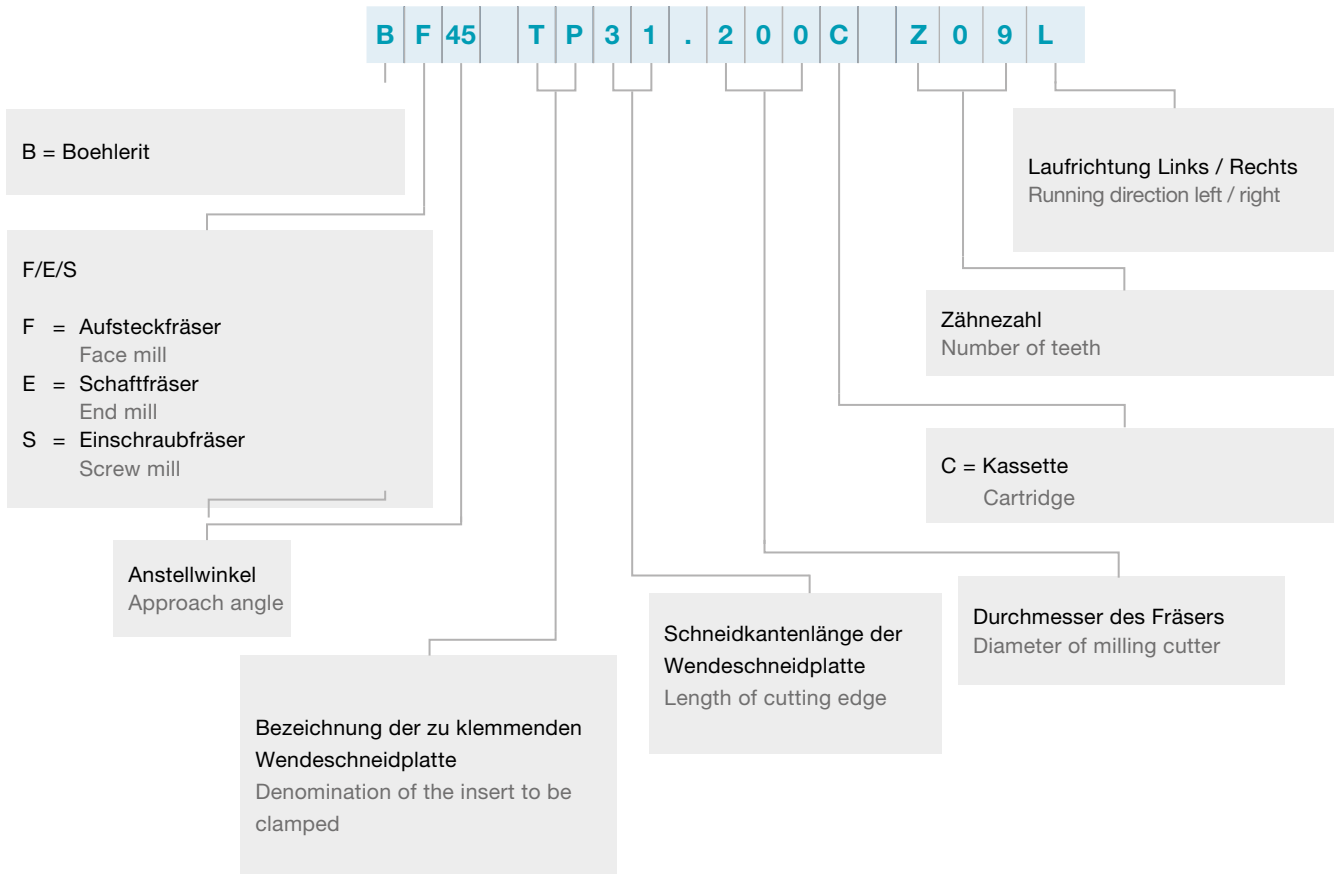

**Schneidstoffsorten, Bezeichnung**  
Cutting Materials, Designation System

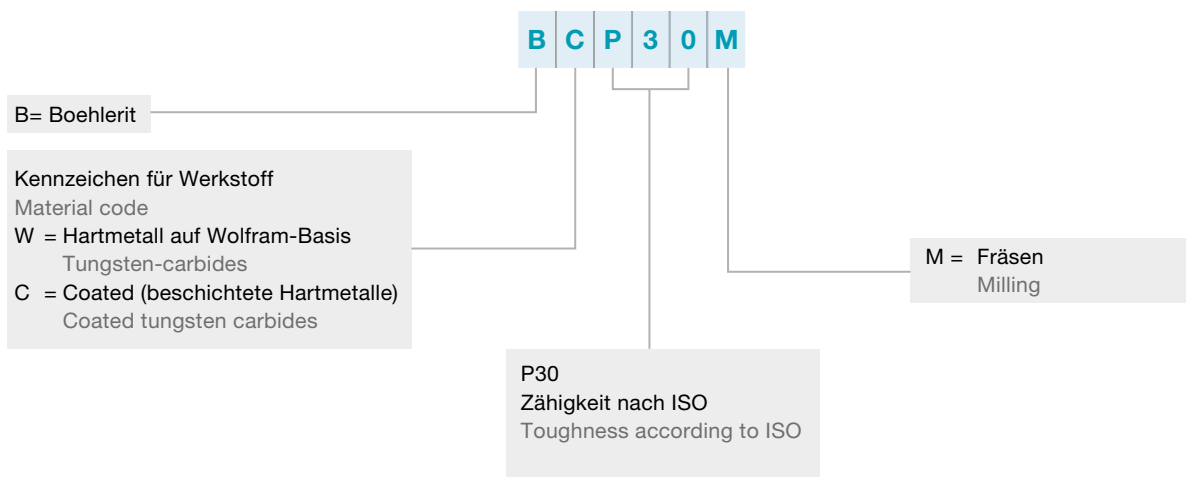

	Werkstoff	Material	R <sub>m</sub> /UTS (N/mm <sup>2</sup> )	Schnittgeschwindigkeit Cutting speed v <sub>c</sub> m/min für Vorschub/Zahn for feed/tooth		
				0,08 - 0,15	0,16 - 0,35	0,30 - 0,60
<b>P</b>	Unlegierter Baustahl	Unalloyed structural steel	- 700			
	Automatenstahl	Free cutting steel	- 700			
	Baustahl	Structural steel	500 - 950			
	Vergütungsstahl, mittelfest	Heat-treatment steel, medium strength	500 - 950			
	Stahlguss	Cast steel	< 950			
	Einsatzstahl	Case hardened steel	< 950			
	Rost- und säurebeständiger Stahl, ferritisch, martensitisch	Stainless steel and acid proof steel ferritic, martensitic	500 - 950			
	Vergütungsstahl, hochfest	Heat-treatment steel, high strength	950 - 1400			
	Nitrierstahl, vergütet	Nitriding steel	950 - 1400			
	Werkzeugstahl	Tool steel	950 - 1400			

**Schnittwertempfehlungen für BCM40M**  
Cutting data recommendations for BCM40M

	Werkstoff	Material	R <sub>m</sub> /UTS (N/mm <sup>2</sup> )	Schnittgeschwindigkeit Cutting speed v <sub>c</sub> m/min für Vorschub/Zahn for feed/tooth		
				0,08 - 0,15	0,16 - 0,35	0,30 - 0,60
<b>M</b>	Rost- und säurebeständiger Stahl, austenitisch	Stainless steel and acid proof steel austenitic	500 - 950			
	Martensitaushärtbarer Stahl	Maraging steel				

**Schnittwertempfehlungen für BWN20M**  
Cutting data recommendations for BWN20M

	Werkstoff	Material	R <sub>m</sub> /UTS (N/mm <sup>2</sup> )	Schnittgeschwindigkeit Cutting speed v <sub>c</sub> m/min für Vorschub/Zahn for feed/tooth		
				0,08 - 0,15	0,16 - 0,35	0,30 - 0,60
<b>N</b>	Rein-Metalle, weich	Pure metals, soft	- 500			
	Aluminium-Legierungen, langspanend	Aluminium alloys, long chipping	- 500			
	Aluminium-Legierungen, kurzspanend	Aluminium alloys, short chipping	- 400			
	Kupfer-Legierungen, langspanend	Copper alloys, long chipping	300 - 700			
	Kupfer-Legierungen, kurzspanend	Copper alloys, short chipping	- 500			
	Magnesium-Legierungen	Magnesium alloys	160 - 300			
	Thermoplaste	Thermoplastics	40 - 70			
	Duroplaste	Duroplastics	20 - 40			
	Graphit	Graphite				

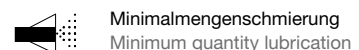
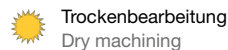
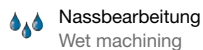



**Vollhartmetall-  
Verlängerungen**

**Solide Carbide  
Extensions**

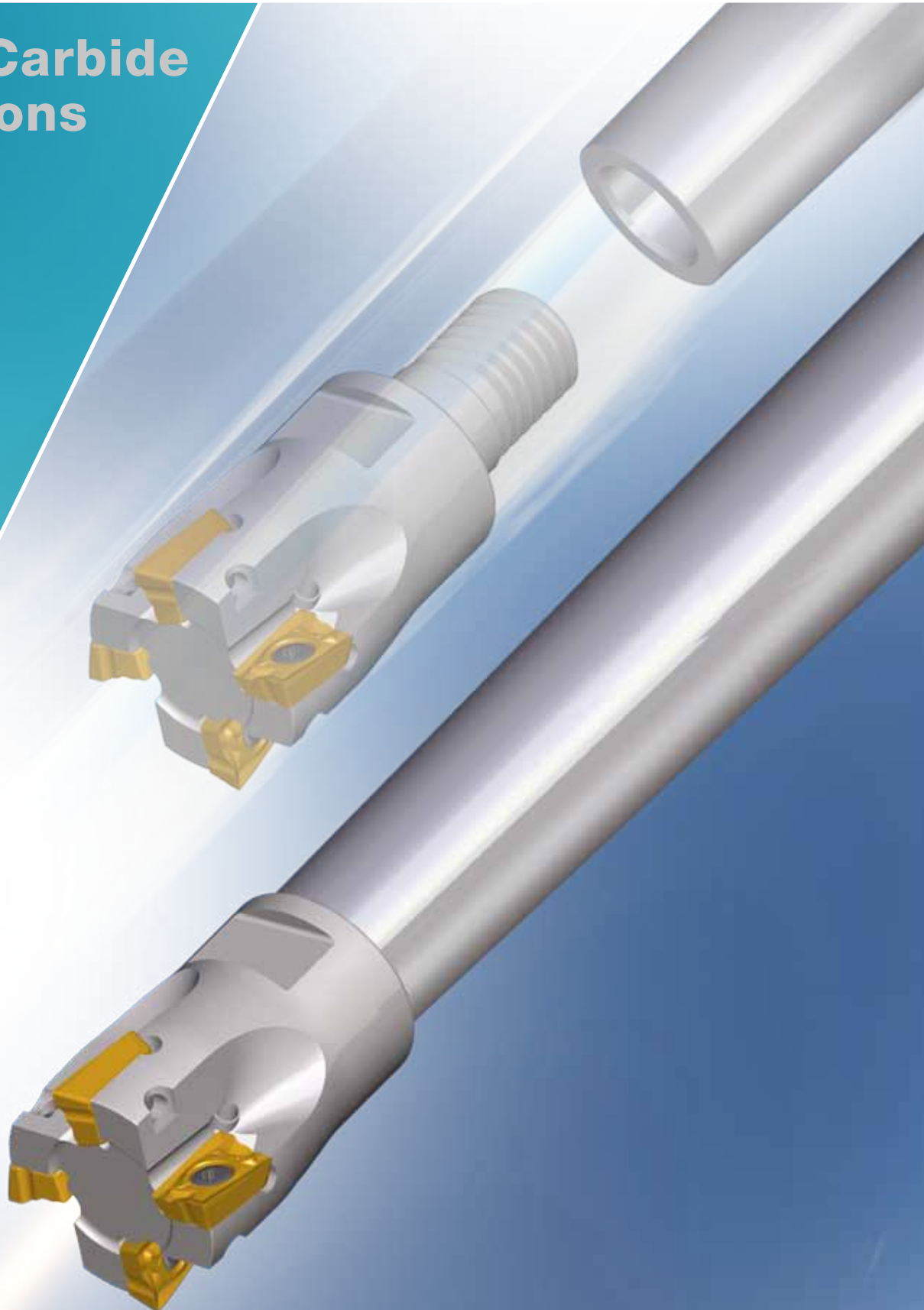

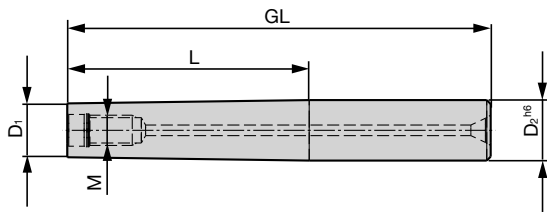



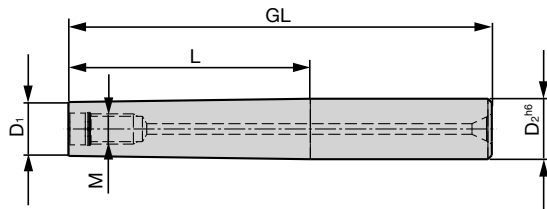

M	D <sub>1</sub>	D <sub>2</sub> <sup>h6</sup>	L <sub>1</sub>	GL	Material-Nr. Material-No.	Bestellbezeichnung Ordering code
8	12,8	16	40	95	5087764	K 16.040 M8
8	12,8	16	60	115	5088441	K 16.060 M8
8	12,8	16	80	135	5088442	K 16.080 M8
8	12,8	16	100	155	5088459	K 16.100 M8
8	12,8	16	120	175	5088462	K 16.120 M8

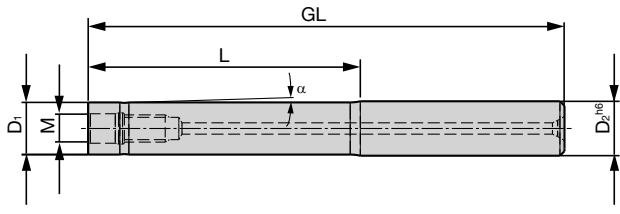

M	D <sub>1</sub>	D <sub>2</sub> <sup>h6</sup>	L <sub>1</sub>	GL	Material-Nr. Material-No.	Bestellbezeichnung Ordering code
10	17,8	20	40	100	5088552	K 20.040 M10
10	17,8	20	60	120	5088553	K 20.060 M10
10	17,8	20	80	140	5088661	K 20.080 M10
10	17,8	20	100	160	5088662	K 20.100 M10
10	17,8	20	120	180	5088768	K 20.120 M10

M	D <sub>1</sub>	D <sub>2</sub> <sup>h6</sup>	L <sub>1</sub>	GL	Material-Nr. Material-No.	Bestellbezeichnung Ordering code
12	23	25	80	136	5088769	K 25.080 M12
12	23	25	100	156	5088776	K 25.100 M12
12	23	25	120	176	5088777	K 25.120 M12
12	23	25	140	196	5088779	K 25.140 M12
12	23	25	160	216	5088781	K 25.160 M12

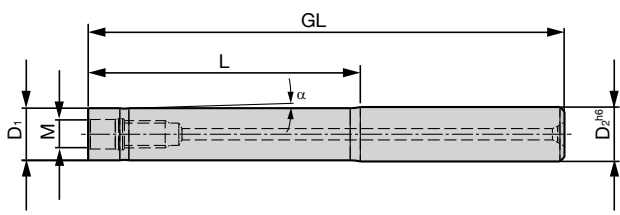
M	D <sub>1</sub>	D <sub>2</sub> <sup>h6</sup>	L <sub>1</sub>	GL	Material-Nr. Material-No.	Bestellbezeichnung Ordering code
16	29	29	100	160	5088789	K 32.100 M16
16	29	29	150	210	5088788	K 32.150 M16
16	29	29	200	260	5088787	K 32.200 M16
16	29	29	250	310	5088786	K 32.250 M16
16	29	29	300	360	5088784	K 32.300 M16

**Aufsteckfräser Face Milling Cutter**

Schrägungswinkel  $W_1$  max beim Rampe eintauchen (Ramping)  
Bevel angle  $W_1$  max. for plunge milling "ramping"

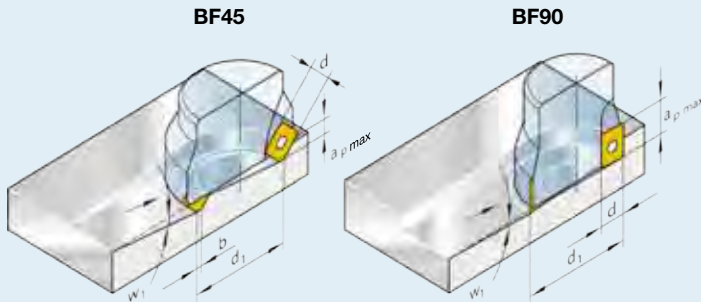

	BF45	BF90	
d	12,7	6,65	9,52
b	1,4		
$a_{p \max}$	5,5	8	14
$d_1$	$W_1$ max Grad Degree		
40	8,5	1,0	1,5
50	6,5	0,8	1,1
63	5,0	0,6	0,8
80	3,5	0,5	0,6
100	3,0		0,5
innere Schnitttiefe: internal cutting depth: $0,7 \times a_{p \max}$			

**Schaftfräser End milling cutter**

Schrägungswinkel  $W_1$  max beim Rampe eintauchen (Ramping)  
Bevel angle  $W_1$  max. for plunge milling "ramping"

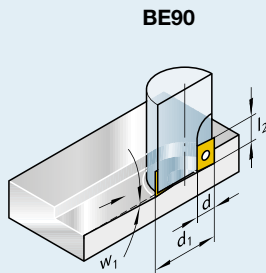

BE90			
$d_1$	$l_2$	d	$W_1$ max Grad Degree
16	8	6,65	3,0
20	8	6,65	2,1
25	8	6,65	1,5
25	14	9,52	2,8
32	14	9,52	2,0
40	14	9,52	1,5

**Formeln  
Formulas**

Drehzahl Revolutions  $n$  ( $\text{min}^{-1}$ ):

$$n = \frac{v_c \cdot 1000}{\pi \cdot d_1}$$

Schnittgeschwindigkeit Cutting speed

$$v_c \text{ (m/min): } v_c = \frac{n \cdot \pi \cdot d_1}{1000}$$

$v_c$  = Schnittgeschwindigkeit Cutting speed (m/min)

$n$  = Drehzahl ( $\text{min}^{-1}$ ) Revolution ( $\text{min}^{-1}$ )

$d_1$  = Fräser-Durchmesser-(mm) Cutter dia. (mm)

$v_f$  = Vorschubgeschwindigkeit Feed rate (mm/min)

$f_z$  = Vorschub pro Zahn Feed per tooth (mm)

$P_e$  = Antriebsleistung Drive power

$z_{\text{eff}}$  = Effektive Zähnezahl effective number of teeth

$Q$  = Spanvolumen Chip volume ( $\text{cm}^3/\text{min}$ )

$a_e$  = Schnittbreite Width of cut (mm)

$a_p$  = Schnitttiefe Depth of cut (mm)

LF = Leistungsfaktor Efficiency factor ( $\text{cm}^3/\text{min}/\text{kW}$ )

Vorschubgeschwindigkeit Feed rate

$v_f$  (mm/min):

$$v_f = f_z \cdot z_{\text{eff}} \cdot n$$

Vorschub pro Zahn Feed per tooth

$$f_z \text{ (mm): } f_z = \frac{v_f}{z_{\text{eff}} \cdot n}$$

Spanvolumen Chip volume- $Q$  ( $\text{cm}^3/\text{min}$ ):

$$Q = \frac{a_e \cdot a_p \cdot v_f}{1000}$$

Antriebsleistung Drive power

$$P_e \text{ (kW): } P_e = \frac{Q}{LF}$$

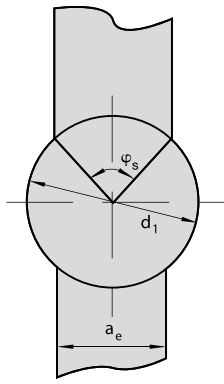
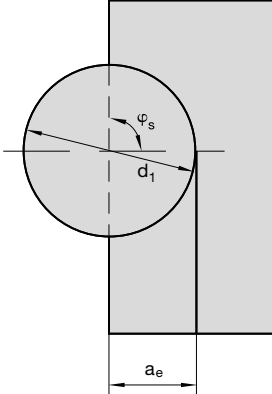
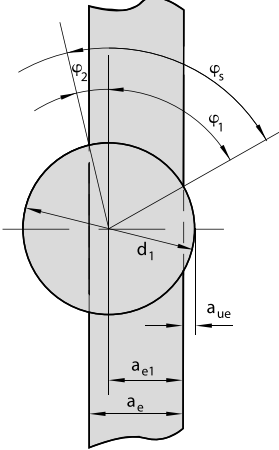

<p>Mittige Anordnung Centerline location</p>	
$\varphi_s = 2 \cdot \sin^{-1} \left( \frac{a_e}{d_1} \right)$	
<p>Kanten fräsen Edge milling</p>	
$\varphi_s = \sin^{-1} \left( \frac{a_e - \frac{d_1}{2}}{\frac{d_1}{2}} \right) + 90$ $n = \frac{v_c \times 1000}{\pi \cdot d_e}$	<p><b>Anhang Attachment</b></p> 
<p>Versetzt fräsen Adjusted milling</p>	
$\sin \varphi_1 = \frac{2 \times \left( \frac{d_1}{2} - a_{ue} \right)}{d}$ $\sin \varphi_2 = \frac{2 \times (a_e - a_{e1})}{d_1}$ $\sin \varphi_s = \sin \varphi_1 + \sin \varphi_2$	

Maße und Einheiten Dimensions and units	Anwendungsformeln Application formulas							
<p><math>a_p</math> = Schnitttiefe in mm Depths of cut in mm</p> <p><math>a_e</math> = Schnittbreite in mm Width of cut in mm</p> <p><math>l</math> = Bearbeitete Länge in mm Machined length in mm</p> <p><math>h_m</math> = Mittenspanndicke in mm Medium chip thickness</p> <p><math>v_c</math> = Schnittgeschwindigkeit in m/mm Cutting speed in m/mm</p> <p><math>f_z</math> = Vorschub pro Zahn in mm Feed per tooth in mm</p> <p><math>d_1</math> = Äußerer Werkzeugdurchmesser external tool diameter</p> <p><math>d_e</math> = Effektiver Durchmesser, Schnittkreisdurchmesser in mm Effective diameter with different inserts and at specified cut depth in mm</p> <p><math>d</math> = Durchmesser der Platte in mm Insert diameter in mm</p> <p><math>z</math> = Anzahl der Schneiden am Werkzeug Number of tool cutting edges</p> <p><math>k</math> = Einstellwinkel Setting angle</p> <p><math>\varphi_s</math> = Eingriffswinkel Approach angle</p>	<p>Umdrehungen pro Minute <math>n</math> [U/min] Revolutions per minute <math>n</math> [rpm]</p> $n = \frac{v_c \times 1000}{\pi \cdot d_e}$	<p>Mittlere Spandicke <math>h_m</math> [mm] Medium chip thickness <math>h_m</math> [mm]</p> $h_m = f_z \times \frac{a_e}{d_e}$						
	<p>Vorschubgeschwindigkeit <math>v_f</math> [mm/min] Feed rate <math>v_f</math> [mm/min]</p> $v_f = f_z \cdot n \cdot z$	<p>gültig nur bis valid only up to <math>\frac{a_e}{d_e} &lt; 0,3</math> bzw. 30% oder <math>\varphi = 60^\circ</math> sonst otherwise <math>h_m = \frac{360 \times f_z \times a_e \times \sin(k)}{\pi \cdot d_e \varphi_s}</math></p>						
	<p>Vorschub pro Umdrehung <math>f</math> [mm/U] Feed per revolution <math>f</math> [mm/rev.]</p> $f = \frac{v_f}{n}$	<p>Zerspanungsvolumen <math>Q</math> [cm<sup>3</sup>/min] Chip removal rate <math>Q</math> [cm<sup>3</sup>/min]</p> $Q = \frac{a_p \times a_e \times v_f}{1000}$						
	<p>Vorschub pro Zahn <math>f_z</math> [mm/z] Feed per tooth <math>f_z</math> [mm/tooth]</p> $f_z = h_m \times \sqrt{\frac{d_e}{a_e}}$ <p>gültig nur bis valid only up to <math>\frac{a_e}{d_e} &lt; 0,3</math> bzw. 30 % oder <math>\varphi = 60^\circ</math> respectively 30 % or <math>\varphi 60^\circ</math></p>	<p>Effektiver Schnittkreisdurchmesser [mm] Effective diameter of cutting</p> $d_e = d_1 - d + 2 a_p \sqrt{(d - a_p)}$						
	<p>Einstellwinkel <math>k</math> Setting angle</p> <table border="1"> <tr> <td>90°</td> <td><math>f_z</math></td> </tr> <tr> <td>45°</td> <td><math>f_z \cdot 1,414</math></td> </tr> <tr> <td>30°</td> <td><math>f_z \cdot 2</math></td> </tr> </table>	90°	$f_z$	45°	$f_z \cdot 1,414$	30°	$f_z \cdot 2$	<p>Vorschub pro Zahn <math>f_z</math> Feed per tooth</p>
	90°	$f_z$						
	45°	$f_z \cdot 1,414$						
	30°	$f_z \cdot 2$						
	<p>sonst otherwise <math>f_z = \frac{h_m \times \pi \times d_e \times \varphi_s}{360 \times a_e \times \sin(k)}</math></p>							

Abhilfe und Lösungen Removal and solutions	Problem Problem										
	Freiflächenverschleiß Flank wear	Kolkverschleiß Crater wear	Plattenabsplitterungen Flaking	Kammrisse Thermal cracks	Ermüdungsrisse Fatigue cracks	Plastische Verformung Plastic deformation	Kerbverschleiß Notch wear	Aufbauschneidenbildung Built-up edge	Schneidkantenbruch Cutting edge failure	Vibrationen Vibrations	Schlechte Oberflächenqualität Poor surface quality
Verschleißfestere HM-Sorte Carbide grade with higher wear resistance	•	•				•	•				•
Zähere HM-Sorte Tougher carbide grade			•	•	•				•		
Schnittgeschwindigkeit erhöhen Increase cutting speed			•					•			
Schnittgeschwindigkeit verringern Reduce cutting speed	•	•		•		•					
Vorschub pro Zahn erhöhen Increase feed per tooth	•							•		•	
Vorschub pro Zahn verringern Reduce feed per tooth			•	•	•	•	•		•		•
Fräserpositionierung ändern Change cutter position					•					•	
Kleinerer Fräserdurchmesser Smaller cutter diameter				•							
Stabilität verbessern Improve rigidity			•				•		•		
Verwendung einer beschichteten Sorte Use coated grade	•	•						•			
Kühlmittel verwenden Use coolant				•		•					

ISO	Deutschland Germany		USA U.S.A.	Frankreich France	Italien Italy	Großbritannien Great Britain	Europa Norm European Standard
	W-Nr.	DIN	AISI/SAE	AFNOR	UNI	BS	EN
<b>P</b>	Baustahl und Vergütungsstahl Construction steels						
	1.0572	St52-3	A570Gr50	A50-2	Fe490	Fe490-2FN	–
	1.0501	C35	1035	CC35	C35	060A35	–
	1.0503	C45	1045	CC45	C45	080M46	–
	1.0601	C60	1060	CC55	C60	080A62	43D
	1.0715	9SMn28	1213	S250	CF9SMn28	230M07	–
	1.0718	9SMnPb28	12L13	S250Pb	CF9SMnPb28	–	–
	1.0722	10SPb20	–	10PbF2	CF10SPb20	–	–
	1.1141	Ck15	1015	XC12	C16	080M15	32C
	1.1157	40Mn4	1039	35M5	–	150M36	15
	1.1158	Ck25	1025	–	–	–	–
	1.1167	36Mn5	1335	40M5	–	–	–
	1.1191	Ck45	1045	XC42	C45	080M46	–
	1.1203	Ck55	1055	XC55	C50	070M55	–
	1.1221	Ck60	1060	XC60	C60	080A62	43D
	1.1274	Ck101	1095	–	–	060A96	–
	1.3401	X120Mn12	–	Z120M12	G-X120Mn12	Z120M12	–
	1.3505	100Cr6	52100	100C6	100Cr6	534A99	31
	1.5026	100Cr6	9255	55S7	55Si8	250A53	45
	1.5415	15Mo3	ASTM A204Gr.A	15D3	16Mo3KW	1501-240	–
	1.5622	14Ni6	ASTM A350LF5	16N6	14Ni6	–	–
	1.5662	X8Ni9	ASTM A353	–	X10Ni9	1501-509;510	–
	1.5680	12Ni19	2515	Z18N5	–	–	–
	1.5710	36NiCr6	3135	35NC6	–	640A35	111A
	1.5752	14NiCr14	3415; 3310	12NC15	–	655M13	36A
						655A12	
	1.6511	36CrNiMo4	9840	40NCD3	38NiCrMo4(KB)	816M40	110
	1.6546	40NiCrMo22	8740	–	40NiCrMo2(KB)	311-Type 7	–
	1.6580	30CrNiMo8	–	30CrNiMo8	30CrNiMo8	–	–
	1.6587	17CrNiMo6	–	18NCD6	–	820A16	–
	1.6657	14NiCrMo134	–	–	15NiCrMo13	832M13	36C
	1.7015	15Cr3	5015	12C3	–	523M15	–
	1.7033	34Cr4	5132	32C4	34Cr4(KB)	530A32	18B
	1.7131	16MnCr5	5115	16MC5	16MnCr5	(527M20)	–
	1.7176	55Cr3	5155	55C3	–	527A60	48
	1.7218	25CrMo4	4130	25CD4	25CrMo4(KU)	1717CDS110	–
	1.7220	34CrMo4	4137; 4135	35CD4	35CrMo4	708A37	19B
	1.7225	42CrMo4	4140	42CD4	42CrMo4	708M40	19A
	1.7335	13CrMo4 4	ASTM A182 F11 F12	15CD3.5 15CD4.5	14CrMo4 5	1501-620Gr27	–
	1.7361	32CrMo12	–	30CD12	32CrMo12	722M24	40B
	1.7380	10CrMo9 10	ASTM A182 F.22	12CD9, 10	12CrMo9, 10	1501-622 Gr.31;45	–
	1.7715	14MoV6 3	–	–	–	1503-660-440	–
	1.8159	50CrV4	6150	50CV4	50CrV4	735A50	47
	1.8504	34CrAl6	–	–	–	–	–
	1.8509	41CrAlMo7	–	40CAD6, 12	41CrAlMo7	905M39	41B
	1.8523	39CrMoV13 9	–	–	36CrMoV12	897M39	40C

ISO	Deutschland Germany		USA U.S.A.	Frankreich France	Italien Italy	Großbritannien Great Britain	Europa Norm European Standard
	W-Nr.	DIN	AISI/SAE	AFNOR	UNI	BS	EN
<b>P</b>	Werkzeugstähle Tool steels						
	1.1545	C105W1	–	Y1105 C100KU	C98KU	–	–
	1.2067	100Cr6	L3	Y100C6	–	BL3	–
	1.2080	X210Cr12	D3	Z200C12 X250Cr12KU	X210Cr13KU	BD3	–
	1.2343	X38CrMoV5 1	H11	Z38CDV5	X37CrMoV51(KU)	BH11	–
	1.2344	X40CrMoV5 1	H13	Z40CDV5 X40CrMoV511KU	X35CrMoV05KU	BH13	–
	1.2363	X100CrMoV 5 1	A2	Z100CDV5	X100CrMoV51KU	BA2	–
	1.2379	X155CrVMo12 1	D2	Z160CDV12	X155CrVMo121KU	BD2	–
	1.2419	105WCr6	–	105WC13 107WCr5KU	10WCr6	–	–
	1.2436	X210CrW12	–	–	X215CrW12 1KU	–	–
	1.2542	45WCrV7	S1	–	45WCrV8KU	BS1	–
	1.2581	X30WCrV9 3	H21	Z30WCV9 X30WCrV9 3KU	X28W09KU	BH21	–
	1.2601	X165CrMoV12	–	–	X165CrMoV12KU	–	–
	1.2713	55NiCrMoV6	L6	55NCDV7	–	–	–
	1.2833	100V1	W210	Y1105V	–	BW2	–
	1.3243	S 6-5-2-5	M41	Z85WDKCV	HS 6-5-2-5	–	–
	<b>M</b>	Nichtrostende und warmfeste Stähle Stainless and heat resistant steels					
1.4016		X8Cr17	430	Z8C17	X8Cr17	430S15	60
1.4027		G-X20Cr14	–	Z20C13M	–	420C29	56B
1.4034		X46Cr13	–	Z40CM Z38C13M	X40Cr14	420S45	56D
1.4057		X22CrNi17	431	Z15CNi6.02	X16CrNi16	431S29	57
1.4104		X12CrMoS17	430F	Z10CF17	X10CrS17	–	–
1.4113		X6CrMo17	434	Z8CD17.01	X8CrMo17	434S17	–
1.4122		X35CrMo17	–	–	–	–	–
1.4313		X5CrNi13 4	–	Z4CND13.4M	–	425C11	–
1.4718		X45CrSi9 3	HW3	Z45CS 9	X45CrSi8	401S45	52
1.4724		X10CrAl13	405	Z10C13	X10CrAl12	403S17	–
1.4742		X10CrAl18	430	Z10CAS18	X8Cr17	430S15	60
1.4747		X80CrNiSi20	HNV6	Z80CSN20.02	X80CrSiNi20	443S65	59
1.4762		X10CrAl24	446	Z10CAS24	X16Cr26	–	–
1.4871		X53CrMnNiN 219	EV8	Z52CMN21.09	X53CrMnNiN21 9	349S54	–

ISO	Deutschland Germany		USA U.S.A.	Frankreich France	Italien Italy	Großbritannien Great Britain	Europa Norm European Standard
	W-Nr.	DIN	AISI/SAE	AFNOR	UNI	BS	EN
<b>M</b>	Rost- und säurebeständige Stähle Rust- and acid-proof steels						
	1.4301	X5CrNi189	304	Z6CN18.09	X5CrNi18 10	304S15	58E
	1.4305	X12CrNiS18 8	303	Z10CNF18.09	X10CrNiS 18.09	303S21	58M
	1.4308	G-X6CrNi18 9	–	Z6CN18.10M	–	304C15	–
	1.4311	X2CrNiN 18 10	304LN	Z2CN18.10	–	304S62	–
	1.4362	X2CrNiN 23 4	S32304	–	–	–	–
	1.4401	X5CrNiMo 18 10	316	Z6CND17.11	X5CrNiMo17 12	316S16	–
	1.4408	G-X6CrNiMo 18 10	–	–	–	316C16	–
	1.4417	X2CrNiMoSi 19 5	S31500	–	–	–	–
	1.4429	X2CrNiMoN 18 13	316LN	Z2CND17.13	–	–	–
	1.4438	X2CrNiMo18 16	317L	Z2CND19.15	X2CrNiMo18 16	317S12	–
	1.4460	X8CrNiMo27 5	S32900	–	–	–	–
	1.4462	X2CrNiMoN 22 53	S31803	–	–	–	–
	1.4541	X10CrNiTi 18 9	321	Z6CNT18.10	X6CrNiTi18 11	2337	321S12
	1.4542	X5CrNiCuNb174	630	–	–	–	–
	1.4550	X10CrNiNb 18 9	347	Z6CNNb18.10	X6CrNiNb18 11	347S17	58F
	1.4571	X10CrNiMo18 10	316Ti	Z6NDT17.12	X6CrNiMoTi1712	320S17	58J
	1.4581	G-X5CrNi	–	Z4CNDNb	XG8CrNiMo	318C17	–
		MoNb 18 10	–	18 12M	18 11	–	–
	1.4583	X10CrNi	318	Z6CNDNb	X6CrNiMoNb	–	–
		MoNb 18 12	–	17 13B	17 13	–	–
	1.4828	X15CrNiSi20 12	309	Z15CNS20.12	–	309S24	–
	1.4845	X12CrNi25 21	310S	Z12CN25 20	X6CrNi25 20	310S24	–
	1.4864	X12NiCrSi36 16	330	Z12NCS35.16	–	–	–
	1.4865	G-X40NiCrSi38 18	–	–	XG50NiCr39 19	330C11	–
	1.4878	X12CrNiTi18 9	321	Z6CNT18.12B	X6CrNiTi1811	32S12	58B
	<b>K</b>	Gusseisen mit Lamellengrafit Grey cast iron (plain carbon)					
0.6015		GG15	No 25B	Ft 15 D	–	Grade 150	EN GJL-150
0.6025		GG25	No 35B	Ft 25 D	–	Grade 260	EN GJL-250
0.6035		GG35	No 50B	Ft 35 D	–	Grade 350	EN GJL-350
0.6040		GG40	No 55B	Ft 40 D	–	Grade 400	EN GJL-400
Austenitisches Gusseisen mit Lamellengrafit Grey cast iron (alloy)							
0.6660		GGL-NiCr 20 2	A436-72	L-NC 20 2	–	L-NiCr 20 2	EN GJLA-X NiCuCr 15-6-2
0.6680		GGL-NiCr 3055	–	–	–	–	EN GJLA-X NiCuCr 15-6-2
Gusseisen mit Kugelgrafit Spheroidal graphite cast iron (plain carbon)							
0.7040		GGG 40	60-40-18	FCS 400-12	–	SNG 420/12	EN GJ5-400-15
0.7060		GGG 60	–	FGS 600-3	–	SNG 600/3	EN GJ5-600-3
0.7070		GGG 70	100-70-03	FGS 700-2	–	SNG 700/2	EN GJ5-700-2
Austenitisches Gusseisen mit Kugelgrafit Spheroidal graphite cast iron (alloy)							
0.7652		GGG NiMn 13 7	–	L-NM 13 7	–	L-NiMn 13 7	EN GJLA-X NiCuCr 15-6-2
0.7660		GGG NiCr 20 2	–	L-NC 20 2	–	L-NiMn 20 2	–
Temperguss schwarz Malleable cast iron							
0.8135		GTS-35-04	32510	MN 35-10	–	B 340/12	EN GJMB-350-10
0.8155		GTS-55-04	50005	MP 50-5	–	P 510/4	EN GJMB-550-4
0.8170		GTS-70-02	–	IP 70-2	–	P 690	EN GJMB-700-2

ISO	Deutschland Germany		USA U.S.A.	Frankreich France	Italien Italy	Großbritannien Great Britain	Europa Norm European Standard
	W-Nr.	DIN	AISI/SAE	AFNOR	UNI	BS	EN
<b>N</b>	NE-Schwermetall-Legierungen Non-ferrous heavy metal alloys						
	2.0321	CuZn37(Ms63)	C27400	CuZn37	P-CuZn37	CZ 108	CW508L
	2.0402	CuZn40Pb2(Ms58)	C37700	CuZn39Pb2	P-CuZn3940Pb2	CZ 122	CW617N
	2.0872	CuNi10Fe1Mn	C70600	CuNi10Fe1Mn	Pt-CuNi10Fe1Mn	CZ 135	CW352H
	2.0920	CuAl8			P-CuAl8		
	2.0932	CuAl8Fe3	C61400	CuAl7Fe2	P-CuAl8Fe3	CA106	CW303G
	2.0966	CuAl10Ni5Fe4	C63000	CuAl10Ni5Fe4		CA104	CW307G
	2.0975	CuAl10Ni	C95800	CuAl10Fe5Ni5	CuAl11Fe4Ni4	AB2	
	2.1020	CuSn6	C51900	CuSn6P	CuSn7	PB103	CW452K
	2.1498	CuSP			CuS(P0,01)		
	2.3205	PbSb5					
	2.3290	PbSb9					
	Leichtmetall-Legierungen Light metal alloys						
	3.1355	AlCuMg2	AA 2024	2024	2024	2024	AW-2024
	3.1645	AlCuMgPb					AW-2007
	3.2581.01	AlSi12	B413.0	A-S 13	3051/G-AS9MG	LM6	AC-44200
	3.3527	AlMg2Mn0,8					AW-5049
	3.3535	AlMg3	AA 5754	5754			AW-5754
	3.4365	AlZnMgCu1,5	AA 7075	7075	7075	7075	AW-7075
	3.5312	MgAl3Zn	AZ31B	G-A3Z1		MAG-E-111	MG-P-62
3.5161	MgZn6Zr	ZK60A			MAG-E-161		
3.5194	MgAl9Zn1	AZ91	G-A9Z1		MAG 7	MC-21120	
3.7115	Ti-5Al-2,5Sn	Grade 6		T-A5E			
3.7165	Ti-6Al-4V	Grade 5		T-A6V	TA10-13	Ti P63	
3.7174	Ti-6Al-6V-2Sn	4971				Ti P64	
<b>S</b>	Hochwarmfeste Werkstoffe High-temperature materials						
	Handelsname						
	Tradename						
	HS-27	NiCo32Cr26Mo			KC20WN		
	Hastelloy-C	NiMo16Cr15W	B366	NC17DWY	N01276		DIN 2.4819
	Inconel 718	NiCr19NbMo	5662		N07718	HR8	DIN 2.4668
	Lescalloy	NiCr16FeTi					
	Nimonic90	NiCr20Co18Ti			N07090		DIN 2.4632
	Unitemp	NiCr16Co8WAlTi					
	Vakumell	NiCr20TiAl					
	Vakumelt	NiCo10Cr9WAlTi					
	Alloy 625	NiCr22Mo9N	5599		N06625	NA21	DIN 2.4856

## Argentinien/Argentina

SIN PAR S.A.  
Conesa 10  
B1878KSB Quilmes -  
Buenos Aires  
Telefon +54 11 4257 4396  
Telefax +54 11 4224 5687  
ventas@sinpar.com.ar  
www.sinpar.net  
www.boehlerit.com

## Brasilien/Brazil

Boehlerit Brasil Ferramentas Ltda.  
Rua Capricórnio, 72  
Alpha Conde I Comercial  
06473-005 - Barueri -  
São Paulo  
Telefon +55 11 554 60 755  
Telefax +55 11 554 60 476  
info@boehlerit.com.br  
www.boehlerit.com.br

## China/China

Boehlerit China Co. Ltd.  
Swiss Center Shanghai  
Room A107, Building 3  
No. 526, 3rd East Fute Road  
200131 Shanghai Pilot Free  
Trade Zone  
Telefon +86 137 358 950 58  
info@boehlerit.com.cn  
www.boehlerit.com

## Deutschland/Germany

Boehlerit GmbH & Co. KG  
Werk VI-Strasse 100  
8605 Kapfenberg  
Österreich/Austria  
Telefon +43 3862 300-0  
Telefax +43 3862 300-793  
info@boehlerit.com  
www.boehlerit.com

## Dubai/Dubai

HFD Electronic Spare Parts LLC  
The Curve Bldg. SZR  
Office M40, P.O. Box 6293  
Dubai, United Arab Emirates  
Telefon +971 4 380 7866  
Telefax +971 4 380 7867  
chris@hfdme.ae  
www.hfdme.com  
www.boehlerit.com

## Finnland/Finland

Oy Maanterä AB  
Keinmäenkuja 2, P.O. Box 70  
01510 Vantaa  
Telefon +358 29 006 130  
Telefax +358 29 006 1130  
maantera@maantera.fi  
www.maantera.fi  
www.boehlerit.com

## Italien/Italy

Boehlerit Italy S.r.l.  
Via Papa Giovanni XXIII, Nr. 45  
20090 Rodano (MI)  
Telefon +39 02 269 49 71  
Telefax +39 02 218 72 456  
info@boehlerit.it  
www.boehlerit.com

## Kroatia/Bosnien & Herzegovina

Croatia/Bosnia & Herzegovina  
Mikra d.o.o.  
Bana J. Jelacica 25a  
HR- 47250 Duga Resa  
Telefon +385 47 84 47 41  
Telefax +385 47 84 14 29  
info@mikra-tools.com  
www.mikra-tools.com

## Mexiko/Mexico

Boehlerit S.A. de C.V.  
Av. Acueducto No. 15  
Parque Industrial Bernardo  
Quintana  
El Marqués, Querétaro  
México. C.P. 76246  
Telefon +52 442 221 5706  
Telefax +52 442 221 5555  
info@boehlerit.com.mx  
www.boehlerit.com

## Niederlande/Netherlands

Hagro Precisie b.v.  
Industriepark 18  
NL-5374 CM Schaijk  
Telefon +31 486 462 424  
Telefax +31 486 461 650  
hagro@hagro.nl  
www.hagro.nl  
www.boehlerit.com

## Polen/Poland

Boehlerit Polska sp.z.o.o.  
Złotniki, ul. Kobaltowa 6  
62-002 Suchy Las  
Telefon +48 61 659 38 00  
Telefax +48 61 623 20 14  
info@boehlerit.pl  
www.boehlerit.com

## Russland/Russia

000 "Metin Group"  
Skladochnaya, 6  
127018, Moscow  
Telefon +7 495 921 1342  
Telefax +7 495 921 1342  
www.metingroup.ru  
www.boehlerit.com

## Schweiz/Switzerland

Vargus Werkzeugtechnik Snel AG  
Knonauerstraße 56  
6330 Cham 1  
Telefon +41 41 784 21 21  
Telefax +41 41 784 21 39  
info@vargus.ch  
www.vargus.ch  
www.boehlerit.com

## BOEHLERIT GmbH & Co. KG

Werk VI-Strasse 100  
8605 Kapfenberg  
Österreich/Austria  
Telefon +43 3862 300 - 0  
Telefax +43 3862 300 - 793  
info@boehlerit.com  
www.boehlerit.com

## Singapur/Singapore

Boehlerit Asia Pte Ltd  
1 Clementi Loop 04-01  
Clementi West District Park  
Singapore 12 98 08  
Telefon +65 64 62 1608  
Telefax +65 64 62 4215  
info@boehlerit.com  
www.boehlerit.com

## Slowakei/Slovakia

Werk VI-Strasse 100  
8605 Kapfenberg  
Österreich/Austria  
Telefon +421 910 998 641  
Telefax +43 3862 300 - 479  
peter.kotes@boehlerit.com  
www.boehlerit.sk  
www.boehlerit.com

## Slowenien/Slovenia

KAC trade d.o.o.  
Ložnica pri Žalcu 46  
3310 Žalec  
Telefon: +386 3 710 40 80  
Telefax: +386 3 710 40 81  
info@kactrade.si  
www.kactrade.com  
www.boehlerit.com

## Spanien/Spain

Boehlerit Spain S.L.  
C/. Narcis Monturiol 11-15  
08339 Vilassar de Dalt Barcelona  
Telefon +34 93 750 7907  
Telefax +34 93 750 7925  
info@boehlerit.es  
www.boehlerit.com

## Tschechien/Czech Republic

Kancelár Boehlerit  
Santraziny 753  
760 01 Zlín  
Telefon +420 577 214 989  
Telefax +420 577 219 061  
boehlerit@boehlerit.cz  
www.boehlerit.cz  
www.boehlerit.com

## Türkei/Turkey

Böhler Sert Maden  
ve Takım San. ve Tic. A.Ş.  
Gebze Organize Sanayi Bölgesi  
1600. Sk.No: 1602  
41480 Gebze – Kocaeli  
Telefon +90 262 677 1737  
Telefax +90 262 677 1746  
bohler@bohler.com.tr  
www.bohler.com.tr  
www.boehlerit.com